

Harmonic Filter

谐波滤波器

操作手册

Operation manual

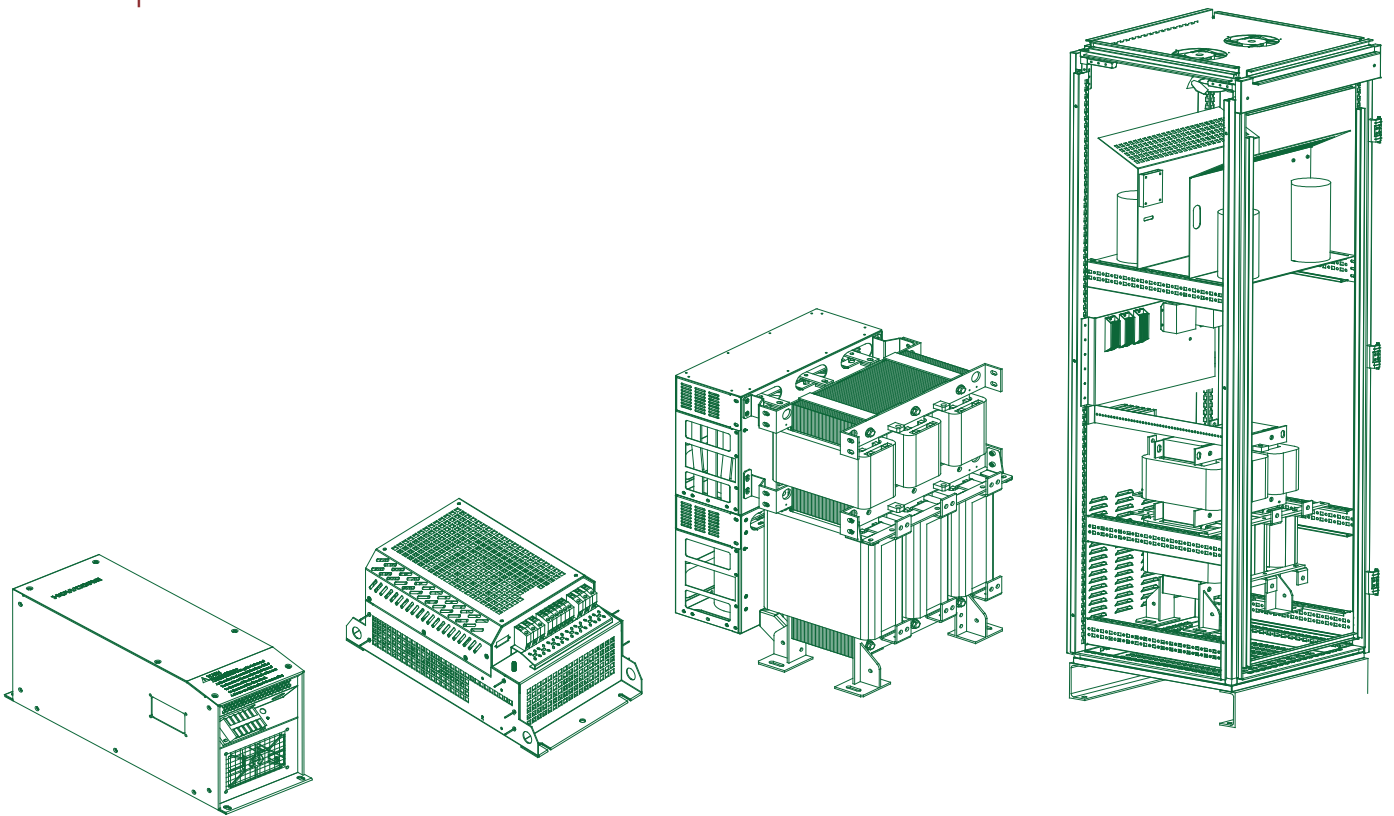

安全须知

Safety instructions



这些安全须知适用于所有工作的本公司的设备。忽视这些说明可能会导致人身伤害和死亡。

These safety instructions apply to all equipment of our company for work. Neglecting these instructions May cause personal injury and death.



禁止带电操作!
Prohibit live operation!

操作人员资格

Operator qualifications

只允许专业从事电气方面工作的人员操作本设备。本设备的安装、运行监测、故障维修只能由专业人员来操作，要求对设备操作的人员必须熟读此手册。

Only professionals engaged in electrical work are allowed to operate this equipment. The installation, operation monitoring, and troubleshooting of this equipment can only be operated by professional personnel. It is required that personnel operating the equipment must read this manual thoroughly.

安装和维护安全

Installation and maintenance of safety

绝不能对已接通电源的谐波滤波器尝试任何操作。切断供应电源后，通常需要等中间回路电容放电5分钟，然后才能对变频器、电机或电机电缆操作。开始操作前，使用电压万用表检查谐波滤波器进出线端子处已经放电完毕。

Never attempt any operation on a harmonic filter that has been powered on. After cutting off the power supply, it is usually necessary to wait for 5 minutes for the intermediate circuit capacitor to discharge before operating the frequency converter, motor, or motor cable. Before starting the operation, use a voltage multimeter to check that the input and output terminals of the harmonic filter have been discharged.

责任免除

Exclusion

用户手册的内容描述了产品的特性，但是通常不是作为产品的保证书。如果遇到任何疑问和问题，请及时与我们联系，避免发生无可挽回的意外!

The content of the user manual describes the characteristics of the product, but it is usually not used as a warranty for the product. If you encounter any questions or problems, please contact us in a timely manner to avoid irreparable accidents!

尊敬的客户:

Dear customer

我司会对本说明进行周期性更新及补遗，恕不另行通知，如有疑问请垂询我司当地经销商!

Our company will periodically update and supplement this manual without prior notice. If you have any questions, please contact our local distributor!

■ 谐波滤波器安全须知

Safety instructions for harmonic filters

1. HFR谐波滤波器是变频器配套的滤波器，只可安装在变频器的电源进线处；
The HFR harmonic filter is a filter that is matched with the frequency converter and can only be installed at the power inlet of the frequency converter;
2. 选用时，滤波器的功率与变频器的功率尽量匹配使用，这时可以获得最佳的滤波效果，不匹配时，功率较大的滤波器可以用于功率较小的变频器，但滤波效果会降低；
When selecting, the power of the filter should be matched with the power of the frequency converter as much as possible to achieve the best filtering effect. If not matched, the filter with higher power can be used for the frequency converter with lower power, but the filtering effect will be reduced;
3. 可以用单台HFR为多台变频器供电，但总负荷不得超过HFR的额定功率值；
Multiple frequency converters can be powered by a single HFR, but the total load must not exceed the rated power value of the HFR;
4. 滤波器中的电抗器是发热设备，安装时注意保持滤波器周围至少有200mm的空间；
The reactor in the filter is a heating device. When installing, be careful to maintain at least 200mm of space around the filter;
5. 滤波器中的电容是温度敏感设备，注意保持电容的环境温度小于50℃；
The capacitor in the filter is a temperature sensitive device. Pay attention to keeping the ambient temperature of the capacitor below 50℃;
6. 安装时，按照电路图的接线指示，连接可靠的地线；
During installation, follow the wiring instructions on the circuit diagram and connect a reliable ground wire;
7. 如需操作谐波滤波器，必须先测量滤波器进出线端子上有无残留危险电压。
If you need to operate a harmonic filter, you must first measure whether there is any residual hazardous voltage on the input and output terminals of the filter.

■ 接地

Grounding

这些安全指导适用于所有对谐波滤波器进行接地操作的工程技术人员。
These safety guidelines apply to all engineering and technical personnel conducting grounding operations on harmonic filters.

警告！ 忽视以下指导会造成人身伤亡，并且会增加电磁干扰和设备损坏；在任何情况下都要将谐波滤波器、传动及其连接设备接地，以保证人身安全，并减少电磁辐射和电磁干扰。

Warning! Neglecting the following guidance can cause personal injury and increase electromagnetic interference and equipment damage; In any case, the harmonic filter, transmission and its connecting equipment must be grounded to ensure personal safety and reduce electromagnetic radiation and interference.

必须保证接地导体的尺寸符合当地安全规范的要求。

It is necessary to ensure that the size of the grounding conductor meets the requirements of local safety regulations.

关于本手册

About this Manual



在安装和操作设备前，应仔细地阅读本手册。
手册中包含了有利于设备完好发挥性能、避免错误操作的必备信息。
以下的符号、术语及名称用于本操作安装手册。
Before installing and operating the equipment, carefully read this manual.
The manual contains essential information that is beneficial for the equipment to perform well and avoid incorrect operations.
The following symbols, terms, and names are used in this operation and installation manual.

表1 符号、术语及名称的使用
Table 1 Use of Symbols, Terminology, and Names

	注释 explanatory note
注意! Attention!	遵循手册要求，防范设备损坏 Follow the manual requirements to prevent equipment damage
	遵循手册要求，防范设备损坏及人身伤害 Follow the manual requirements to prevent equipment damage and personal injury
 Warn	遵循手册要求，防止严重事故发生 Follow the manual requirements to prevent serious accidents from occurring
 Dangerous	遵循手册要求，防止严重事故及致命伤害情况的发生 Follow the manual requirements to prevent serious accidents
 Dangerous	遵循手册要求，防止因危险电压导致的严重事故及致命伤害发生 Follow the manual requirements to prevent serious accidents and fatal injuries caused by hazardous voltages
【注】 【Note】	请关注【注】表述的内容，用于解释说明 Please pay attention to the content expressed in [Note] for explanatory purposes

目录

Directory



1 如何阅读操作手册	05	
How to read the operation manual		
2 谐波及其改善方法简介	05	
Introduction to harmonics and their improvement methods		
2.1 什么是谐波	05	
What is harmonic		
2.1.1 线性负载.....	05	
Linear Load		
2.1.2 非线性负载.....	06	
Nonlinear load		
2.1.3 配电系统中谐波的影响.....	07	
The impact of harmonics in distribution systems		
2.2 谐波限制标准和要求	08	
Harmonic limitation standards and requirements		
2.3 谐波改善.....	10	
Harmonic improvement		
3 谐波滤波器简介.....	10	
Introduction to harmonic filters		
3.1 工作原理	10	
Working principle		
3.1.1 功率因数	11	
Power factor		
3.1.2 电容器断开连接	11	
Capacitor disconnection		
4 谐波滤波器选择.....	12	
Selection of harmonic filters		
4.1 如何选择正确的HFR.....	12	
How to choose the right HFR		
4.1.1 滤波器电流计算	12	
Filter current calculation		
4.1.2 计算实例	12	
Calculation example		
4.1.3 电压升压	12	
Voltage boost		
4.2 型号标签	13	
Model label		
4.3 电气数据.....	14	
Electric data		
4.4 一般说明.....	15	
General instructions		
4.4.1 一般技术数据.....	15	
General technical data		
4.4.2 环境数据.....	15	
Environmental data		
5 如何安装.....	16	
How to install		
5.1 机械安装.....	16	
Mechanical Installation		
5.1.1 机械安装安全要求.....	16	
Mechanical installation safety requirements		
5.1.2 安装.....	16	
Install		
5.1.3 工业外壳安装建议.....	16	
Industrial Housing Installation Recommendations		
5.1.4 通风.....	17	
Ventilate		
5.2 电气安装.....	17	
Electrical installation		
5.2.1 过温保护.....	17	
Over Temperature Protection		
5.2.2 电容器断开连接.....	17	
Capacitor disconnection		
5.2.3 连接示意图.....	18	
connection diagram		
5.2.4 电气原理图.....	19	
Schematic Diagram		
5.2.5 电气连接.....	19	
Electrical connections		
5.2.6 布线.....	20	
Wiring		
5.3 C系列无源谐波滤波器模块.....	21	
C-series passive harmonic filter module		
5.3.1 产品尺寸图.....	26	
Product Dimension Drawing		
5.4 N系列无源谐波滤波器模块.....	27	
N-series passive harmonic filter module		
5.4.1 产品尺寸图.....	27	
Product Dimension Drawing		
5.5 B系列无源谐波滤波器模块.....	28	
B-series passive harmonic filter module		
5.5.1 产品尺寸图.....	28	
Product Dimension Drawing		

1. 如何阅读操作手册

How to read the operation manual

本操作手册介绍了有关变频器高级谐波 滤波器的所有内容。
详细介绍了谐波及减少谐波的方式，
同时提供了安装说明及变频器编程指导。

This operation manual introduces all the content about advanced harmonic filters for frequency converters.
Detailed introduction to harmonics and ways to reduce harmonics,
At the same time, installation instructions and inverter programming guidance are provided.



2. 谐波及其治理方法简介

Introduction to Harmonics and Its Control Methods

2.1 什么是谐波?

What is harmonic

2.1.1 线性负载

Linear Load

在单纯的电阻负载（如白纸灯泡）中正弦电压V施加在一个电阻R上，则产生电流I也是正弦的电流I与电压V相位是相同的。

In a simple resistive load (such as a white paper bulb), a sinusoidal voltage V is applied to a resistor R, resulting in a current I that is also sinusoidal. The phase of the current I and the voltage V is the same.

负载消耗的功率为：

The power consumed by the load is:

$$P=U \times I$$

对于无功负载（如感应电机），虽然电流不再与电压相同，但会滞后于电压，产生小于1的滞后有功功率因数。在采用电容性负载的情况下，电流早于电压，产生小于1的超前有功功率因数。

For reactive loads (such as induction motors), although the current is no longer the same as the voltage, it will lag behind the voltage, resulting in a lagging active power factor of less than 1. In the case of using capacitive loads, the current is earlier than the voltage, resulting in a leading active power factor of less than 1.

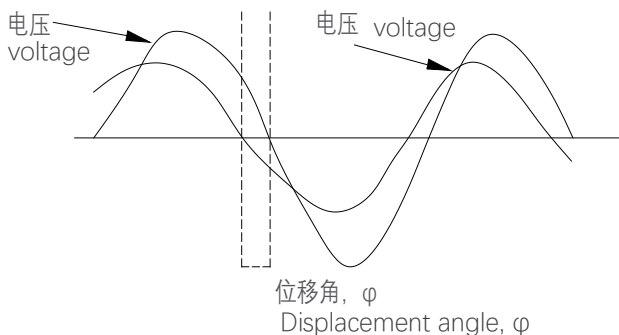

在此种情况下，交流功率包括三个组成部分：

In this case, AC power consists of three components:

有功功率 Active power (P),

无功功率 Reactive power (Q),

和视在功率 Apparent power (S)

视在功率为：

The apparent power is:

$$S=U \times I$$

$$(S=[kVA]、P=[kW] Q=[kVAR])$$

在完美正弦波形的情况下，P,Q和S可表示为行成一个三角形的矢量：

In the case of a perfect sine waveform, P, Q, and S can be expressed as the loss of lines forming a triangle:

$$S^2=P^2+Q^2$$

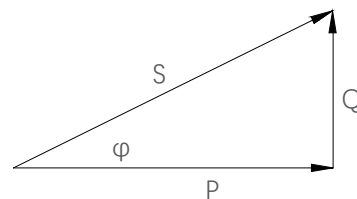

电流与电压之间的位移角为φ。位移功率因数为有功功率(P)与视在功率 (S) 之间的比例：

The displacement angle between current and voltage is φ. The displacement power factor is the ratio between active power (P) and apparent power (S):

$$DPF=\frac{P}{S}=\cos(\varphi)$$

2.1.2 非线性负载

Nonlinear load

非线性负载（如二极管整流器）具有非正弦电流。下图为三相电源上6脉冲整流后电流图,非正弦波形可分解为正弦基波与谐波的总和，谐波是基波的整数倍。

Nonlinear loads (such as diode rectifiers) have non sinusoidal currents. The following figure shows the current diagram after 6 pulse rectification on a three-phase power supply. Non sinusoidal waveforms can be decomposed into the sum of sinusoidal fundamental waves and harmonics, with harmonics being integer multiples of fundamental waves.

$$f(t) = \sum a/h \times \sin(h\omega/1t)$$

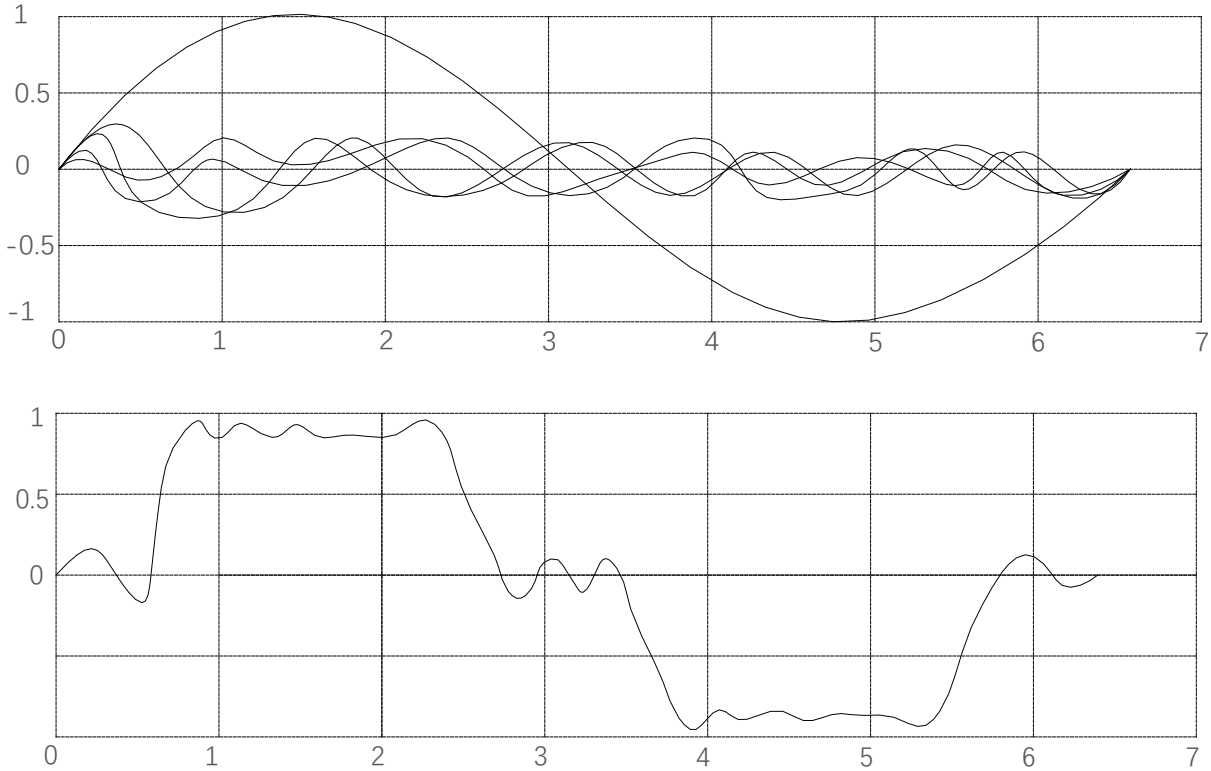

基波频率 ω 的正数倍被称为谐波。非正弦波形的 RMS 值（电流或电压）被表示为：

Positive multiples of the fundamental frequency ω are referred to as harmonics. The RMS value (current or voltage) of a non-sinusoidal waveform is expressed as:

$$I_{RMS} = \sqrt{\sum_{n=2}^{n_{max}} I_n^2}$$

波形中的谐波量给了畸变率，或总谐波畸变率 (THD),用谐波含量的RMS与基本量的RMS值之比表示：

The harmonic content in the waveform gives the distortion rate, or total harmonic distortion rate (THD), expressed as the ratio of the RMS value of the harmonic content to the RMS value of the fundamental quantity:

$$THD = \sqrt{\sum_{n=2}^{n_{max}} \left(\frac{I_n}{I_1}\right)^2} \times 100\%$$

使用THD时，RMS电流 I_{RMS} 和基波电流 I_1 之间的关系和表示为：

When using THD, the relationship and representation between RMS current I_{RMS} and fundamental current I_1 are:

$$I_{RMS} = I_1 \times \sqrt{1 + THD^2}$$

这同样适用于电压。有功率因数PF (λ) 为：

This also applies to voltage. With power factor PF (λ) For:

$$PF = \frac{P}{S}$$

在线性系统中，有功率因数等于位移功率因数：

In a linear system, the power factor is equal to the displacement power factor:

$$PF = DPF = \cos(\varphi)$$

在非线性和系统中，有功功率因数与位移因数之间的关系为：
In nonlinear systems, the relationship between active power factor and displacement factor is:

$$PF = \frac{DPF}{\sqrt{1+THD^2}}$$

功率因数随无功功率和谐波负载降低。低的功率因数会增大RMS电流，增大供电电缆和变压器中的损耗。

The power factor decreases with reactive power and harmonic load. A low power factor will increase RMS current and increase losses in power cables and transformers.

在电网质量分析中，经常会遇到总需求畸变率（TDD）术语。虽然TDD未说明负载特点，但其属于系统参数。TDD以最大需求电流I表示电流谐波畸变。

In power grid quality analysis, the term Total Demand Distortion (TDD) is often encountered. Although TDD does not specify the load characteristics, it belongs to the system parameter. TDD represents current harmonic distortion with the maximum demand current I.

$$TDD = \sqrt{\sum_{h=2}^{h_{max}} \left(\frac{I_h}{I_L}\right)^2} \times 100\%$$

2.1.3 配电系统中谐波的影响

The impact of harmonics in distribution systems

在图2.1中，在初级侧将变压器连接到中压供电的公共合点PCC1。变压器具有阻抗Zxfr且可馈送多个负载。将所有负载连接在一起的公共集合点为PCC2。各负载均同过阻抗为Z1、Z2、Z3的电缆连接。

In Figure 2.1, the transformer is connected to the common junction PCC1 of the medium voltage power supply on the primary side. The transformer has impedance Zxfr and can feed multiple loads. The common collection point that connects all loads together is PCC2. All loads have the same impedance of Z1, Z2, Z3 cable connection for Z3.

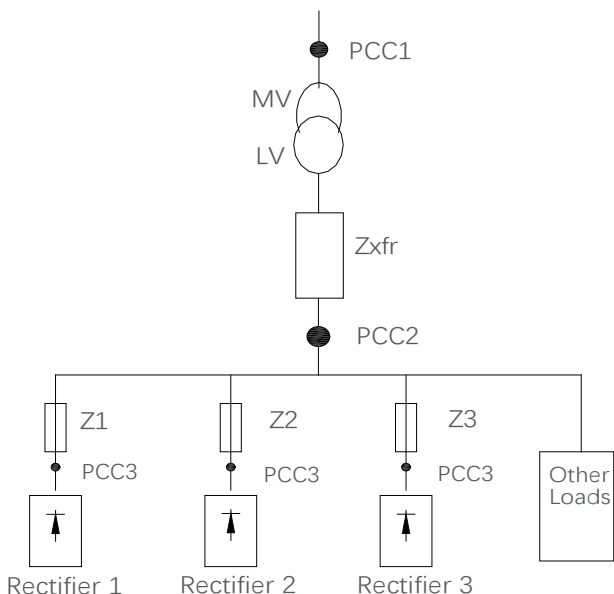

由于配电系统阻抗上压降的原因，非线性负载的谐波电流可导致电压畸变。阻抗越大，电压畸变程度越大。

Due to the voltage drop on the impedance of the distribution system, harmonic currents of nonlinear loads can cause voltage distortion. The larger the impedance, the greater the degree of voltage distortion.

电流畸变与设备性能有关，而设备性能与单个负载有关。电压畸变与系统性能有关。在仅了解负载谐波性能的情况下，无法确定PCC中的电压畸变。为了预测PCC中的畸变，必须了解配电系统配置和相关阻抗。

Current distortion is related to device performance, while device performance is related to individual loads. Voltage distortion is related to system performance. It is not possible to determine voltage distortion in PCC without only understanding the harmonic performance of the load. In order to predict distortion in PCC, it is necessary to understand the distribution system configuration and related impedance.

描述电网阻抗的常用术语为短路比R，其定义是PCC(SCC)点的短路视在功率与负载额定视在功率的比值。

The commonly used term for describing the impedance of the power grid is the short-circuit ratio R, which is defined as the ratio of the short-circuit apparent power at the PCC (SCC) point to the rated apparent power of the load.

$$R_{scc} = \frac{S_{sce}}{S_{equ}}$$

其中 $S_{sc} = \frac{U^2}{Z_{supply}}$ 和 $S_{equ} = U \times I_{equ}$

谐波的副作用为两个部分：

The side effects of harmonics have two parts:

- 谐波电流会造成系统损耗（敷设电缆，变压器）。
Harmonic currents can cause system losses (laying cables, transformers)

- 谐波电压畸变会对其他负载造成干扰并增加其他负载的损耗。

Harmonic voltage distortion can cause interference to other loads and increase their losses.

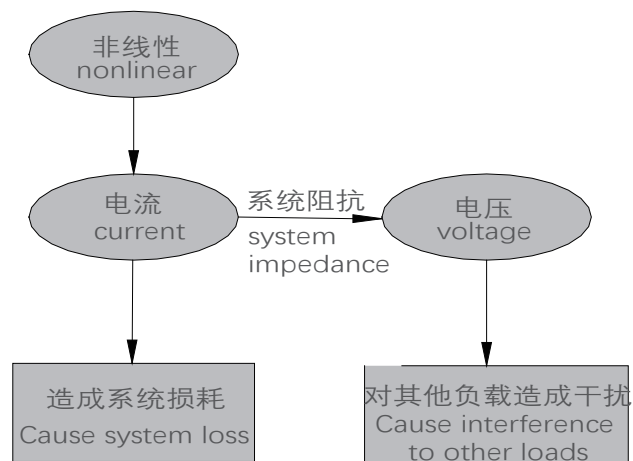

2.2 谐波限制的标准和要求

Standards and requirements for harmonic limitation

谐波限制的要求可以为：

The requirements for harmonic limitation can be:

- 特定应用的要求
Specific application requirements
- 必须遵照的标准要求
Standard requirements that must be followed

特定应用的要求与存在限制谐波技术原因情况下的特定安装有关。

The requirements for specific applications are related to specific installations where there are limitations on harmonic technology.

例如，在两个110KW电机连接的250KVA变压器上。一个直接联机，一个通过变压器供电。如果直接联机电机还需要通过变频器供电，在此种情况下，变压器的尺寸较小要在不更换变压器的情况下改进，必须使用HFR滤波器以减小两个变频器引起的谐波畸变率。

For example, on a 250KVA transformer connected to two 110KW motors. One is directly connected, and the other is powered by a transformer. If the directly connected motor still needs to be powered by a frequency converter, in this case, the smaller size of the transformer needs to be improved without replacing it, and an HFR filter must be used to reduce the harmonic distortion rate caused by the two frequency converters.

有各种谐波改善标准，规定和建议。不同的标准使用于不同的地区和行业。以下为会遇到的标准：

There are various harmonic improvement standards, regulations, and suggestions. Different standards are used in different regions and industries. The following are the standards that will be encountered:

- IEC EN 61000-3-2
- IEC EN 61000-3-12
- IEC EN 61000-3-4
- IEC 61000-2-2
- IEC 61000-2-4
- IEEE 519
- G5/4

IEC 61000-3-2, 谐波电流发射限制（每相位设备输入电流 $\leq 16A$ ）。

IEC 61000-3-2, Harmonic current emission limitation (input current $\leq 16A$ per phase device)

IEC 61000-3-2的范围为连接到公共低压配电系统（每相位输入电流小于等于16A)的设备。四个类别定义如下：A类至D类。

The scope of IEC 61000-3-2 is for equipment connected to public low-voltage distribution systems (with an input current of 16A or less per phase). The four categories are defined as follows: Class A to Class D.

IEC 61000-3-12, 连接到输入电 $> 16A$ 和 $\leq 75A$ 的公共低压系统产生的谐波电流限值。

IEC 61000-3-12, Input current limits for harmonic currents generated by public low-voltage systems $> 16A$ and $\leq 75A$.

IEC 61000-3-12, 范围为 连接到输入电流16A和75A之间的公共低压配电系统的设备。目前发射限值仅限于230、400 V 50HZ系统，以后会增加其他系统的限值。适合变频器的放射限值，请参阅标准中的表4。包括各种谐波（第5次，第7次，第11次和第13次）以及THD和PWHD的要求。Automation Drive系列（FC102HVAC, FC202Aqua和FC302Industry)变频器符合这些限值，无需额外增加滤波器 IEC 61000-3-12, covering equipment connected to public low-voltage distribution systems with input currents between 16A and 75A. At present, the emission limit is limited to 230, 400 V, and 50HZ systems, and limits for other systems will be added in the future. The radiation limits suitable for frequency converters can be found in Table 4 of the standard. Including requirements for various harmonics (5th, 7th, 11th, and 13th) as well as THD and PWHD. The Automation Drive series (FC102HVAC, FC202Aqua, and FC302Industry) frequency converters meet these limits without the need for additional filters.

IEC61000-3-4, 限值，适合电流额定值大于16A的低压电源系统中的设备谐波电流限制电流在小于75A时，IEC61000-3-12优于IEC61000-3-4。

IEC61000-3-4, limits, suitable for equipment in low-voltage power systems with current ratings greater than 16A. When the harmonic current limit is less than 75A, IEC61000-3-12 is superior to IEC61000-3-4.

因此，IEC61000-3-4使用于连接到公共低压配电系统的电流额定值大于75A的设备。作为技术报告部分，不应该被看作是国际标准。三级评估过程适用于设备与公共电源的连接，根据负载既定功率，将高于75A的设备限制为第3级连接。供电部门可接受基于负载安装既定有效功率的设备连接，根据当地供电部门要求。制造商应提供适THD和PWHD的各次谐波的数值。

Therefore, IEC61000-3-4 is used for equipment with a current rating greater than 75A connected to public low-voltage distribution systems. As part of the technical report, it should not be regarded as an international standard. The three-level evaluation process is applicable to the connection between equipment and public power sources. Based on the predetermined power of the load, devices above 75A are limited to the third level connection. The power supply department can accept equipment connections with established effective power based on load installation, according to local power supply department requirements. Manufacturers should provide values for each harmonic of THD and PWHD.

IEC61000-2-2和IEC61000-2-4低频传导骚扰兼容水平。

IEC61000-2-2 and IEC61000-2-4 are compatible with low-frequency conducted disturbances.

IEC61000-2-2和IEC61000-2-4电磁兼容环境2-2,2-4部分：公共低压供电系统低频传导骚扰及信号传输的兼容水平。2-2为公共低压供电系统，2-4为工业设施。

IEC61000-2-2 and IEC61000-2-4 Electromagnetic Compatibility Environment Part 2, 2-4: Compatibility levels for low-frequency conducted disturbances and signal transmission in public low-voltage power supply systems. 2-2 is a public low-voltage power supply system, and 2-4 is an industrial facility.

IEEE 519,IEEE建议的做法和在电力系统中谐波控制的要求。

IEEE 519, IEEE Recommended Practices and Requirements for Harmonic Control in Power Systems.

IEEE519建立了包括性和非线性负载的电气系统设计的目标。确定波形失真目标。和确定电源与负载之间的公共耦合点 (PCC)。

IEEE519 establishes the goal of electrical system design that includes both linear and nonlinear loads. Determine the waveform distortion target. Determine the common coupling point (PCC) between the power supply and the load.

IEEE519是一种系统标准，旨在将PCC点的电压畸变率控制为5%THD，并将各最大频率电压谐波限制为3%。谐波电流限值开发旨在限制各用户的谐波注入，这样就不会产生不可接受电压畸变水平以及超过用电设备所供系统电压总谐波畸变的限制。

IEEE519 is a system standard aimed at controlling the voltage distortion rate of PCC points to 5% THD and limiting the maximum frequency voltage harmonics to 3%. The development of harmonic current limit values aims to limit the harmonic injection of each user, so as not to generate unacceptable voltage distortion levels and exceed the limit of total harmonic distortion of the system voltage supplied by the electrical equipment.

电流畸变限值如标准中的表10.3所示，取决于LSC /IL比，其中ISC为用电设备PCC点的短路电流，IL为最大需求负载电流。这些限值使用于单次谐波（最高至第35次）和总需求畸变（TDD）。请注意。这些限值在用电设备PCC点适用。需要时，符合这些限值的各个负载还要确保PCC点的符合性，这是最经济的解决方案。满足谐波畸变要求最有效的方法就是分别在各个负载进线侧进行改善并在PCC点测量。

The current distortion limit is shown in Table 10.3 of the standard, which depends on the LSC/IL ratio, where ISC is the short-circuit current at the PCC point of the electrical equipment, and IL is the maximum demand load current. These limits are used for single harmonic (up to 35th) and

total demand distortion (TDD). Please note. These limits apply at the PCC point of the electrical equipment. When needed, each load that meets these limits must also ensure the compliance of PCC points, which is the most economical solution. The most effective way to meet the requirements of harmonic distortion is to improve it on each load inlet side and measure it at the PCC point.

然而，如果在指定应用中要求各变频器符合IEEE519电流畸变率限值，则使用AHF就可满足这些限制。

However, if each frequency converter is required to comply with the IEEE519 current distortion rate limit in a specified application, AHF can meet these limitations.

G5/4,工程导则，英国谐波电压畸变和非线性设备接入输电系统和配电网的规划值。

G5/4, Engineering Guidelines, Planning Values for Harmonic Voltage Distortion and Nonlinear Equipment Access to Transmission and Distribution Networks in the UK.

G5/4规定了非线性设备接入过程中所用谐波电压畸变率的规划值。对根据这些规划值确定每位用户发射限值的过程进行说明。G5/4是一个系统级标准。

G5/4 specifies the planned value of harmonic voltage distortion rate used during the connection process of nonlinear equipment. Explain the process of determining the emission limit for each user based on these planning values. G5/4 is a system level standard.

对于400V级点处的THD规划值为5%。400V系统中奇偶谐波限值如标准中表2所示。对非线性设备接入的评估过程进行说明。该过程遵照三级评估程序，旨在使评估过程中所需的细目水平与部分设备连接所造成的不可接受的电压谐波畸变率危险程度保持均衡。

The THD planning value at the 400V level point is 5%. The limit values for odd and even harmonics in a 400V system are shown in Table 2 of the standard. Explain the evaluation process for non-linear device access. This process follows a three-level evaluation procedure, aiming to balance the level of detail required during the evaluation process with the level of unacceptable voltage harmonic distortion caused by some equipment connections.

含有变频器的系统合规性取决于非线性负载的具体拓扑结构和分布。使用HFR就可满足G5/4要求。

The compliance of systems containing frequency converters depends on the specific topology and distribution of nonlinear loads. The use of HFR can meet the G5/4 requirements.

2.3 谐波改善

Harmonic improvement

要改善变频器6脉冲整流器产生的谐波，有几种解决方案，且他们各有各的优缺点。正确解决方案的选择取决于以下几个因素：

There are several solutions to improve the harmonics generated by the 6-pulse rectifier of the frequency converter, each with its own advantages and disadvantages. The choice of the correct solution depends on the following factors:

- . 电网（背景失真，主电源不平衡，谐振以及供电类型--变压器、发电机）
Power grid (background distortion, main power imbalance, resonance, and power supply types - transformers, generators)
- . 应用（负载分布，负载量和负载尺寸）
Application (load distribution, load capacity, and load size)
- . 本地，国家标准，法规（IEEE5119, IEC,G5/4等）
Local, national standards, regulations (IEEE5119, IEC, G5/4, etc.)
- . 总成本（最初成本，效能，维护等）
Total cost (initial cost, efficiency, maintenance, etc.)

不同国家（地区）或跨国组织的IE标准都是一致的。

The IE standards for different countries (regions) or multinational organizations are consistent.

所有上述IEC标准与带前缀 EN 的欧盟标准是一致的。

例如，欧盟EN 61000-3-2与IEC61000-3-2相同。这种情况与前缀AS/NZS澳大利亚和新西兰的情况类似。

All the above IEC standards are consistent with EU standards with the prefix EN. For example, the EU EN 61000-3-2 is the same as IEC61000-3-2. This situation is similar to the prefix AS/NZS in Australia and New Zealand.

谐波解决方案主要有两种类型：无源型与有源型。其中，无源解决方案包括电容器，电抗器或两种不同的装置组合。
There are two main types of harmonic solutions: passive and active. Passive solutions include capacitors, reactors, or two different device combinations.

最简单的解决方案就是在变频器输入侧加装3%至5%电抗器。此电抗器可减少变频器产生的谐波电流量。更先进的无源解决方案电容器和电感器组成的滤波器，以减少从诸如第5次及以上的谐波。

The simplest solution is to install 3% to 5% reactors on the input side of the frequency converter. This inductor can reduce the amount of harmonic current generated by the frequency converter. More advanced passive solutions include filters composed of capacitors and inductors to reduce harmonics such as 5th and above.

有源解决方案具有源分流滤波器监测所有三相的线路电流，并通过一个数字信号处理系统来处理测得的电流信号。滤波器随后主动对电流的多余成分施加反相相位的信号，以执行补偿操作。有源解决方案可改善实时谐波干扰，以使这方案在任何负载分布中非常有效。要了解更多有关有源滤波器的信息，请联系我司销售。

The active solution has a source shunt filter that monitors the line currents of all three phases and processes the measured current signals through a digital signal processing system. The filter then actively applies an inverse phase signal to the excess component of the current to perform compensation operations. Active solutions can improve real-time harmonic interference, making this solution highly effective in any load distribution. To learn more about active filters, please contact our sales representative.

3. 谐波滤波器简介

Introduction to harmonic filters

3.1 工作原理

Working principle

谐波滤波器（HFR）包括主电感器L1和L2和电感器L3以及电容器C组合的二级吸收电路，单元可配装互感器TA以及支路接触器KM，吸收电路需要特别调整，可改善以第5次和第5次以上的谐波电流。基波频率50HZ和基波频率60HZ的电路是不同的基波频率。

The harmonic filter (HFR) includes a secondary absorption circuit consisting of main inductor L1 and L2, inductor L3, and capacitor C combination. The unit can be equipped with transformer TA and branch contactor KM, and the absorption circuit needs special adjustment to improve the harmonic current of the 5th and above. The circuits with a fundamental frequency of 50Hz and 60Hz have different fundamental frequencies.

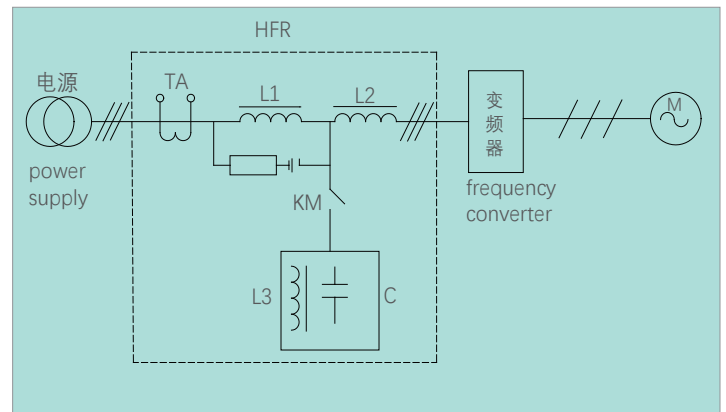

滤波器性能随负载功能的变化而变化。额定负载下，HFR滤波器的性能等于或优于5%（THDi）

The performance of the filter varies with changes in load function. Under rated load, the performance of HFR filters is equal to or better than 5% (THDi).

部分负载情况下，THDi有较高的数值。然而，即使THDi具有较高的数值，谐波电流的绝对值在部分负载情况下较低。因此，部分负载条件下谐波的副作用低于完全负载条件下谐波的副作用。

Under partial load conditions, THDi has a higher value. However, even though THDi has a higher value, the absolute value of harmonic current is lower under partial load conditions. Therefore, the side effects of harmonics under partial load conditions are lower than those under full load conditions.

3.1.1 功率因数

Power factor

在无负载条件下（变频器处于待机状态），变频器电流可以忽略，电网产生的主电流为通过谐波滤波器中电容器的电流。因此，功率因数接近0，具有电容性。电容电流约为滤波器额定电流的25%（取决于滤波器尺寸，20%与25%之间的典型值）。功率因数随负载的增大而增大。

Under no-load conditions (when the frequency converter is in standby mode), the current of the frequency converter can be ignored, and the main current generated by the power grid is the current passing through the capacitor in the harmonic filter. Therefore, the power factor is close to 0 and has capacitance. The capacitance current is approximately 25% of the rated current of the filter (depending on the filter size, typical values between 20% and 25%). The power factor increases with the increase of load.

下图显示了HFR005有效功率因数的典型值。

The following figure shows the typical values of the effective power factor of HFR005.



图3.1 HFR005

3.1.2 电容器段开连接

Open connection of capacitor section

如果应用在无负载情况下需要较高的功率因数且在待机情况下需要降低电容电流，则应断开电容器连接。接触器可在负载低于20%时断开电容器连接。

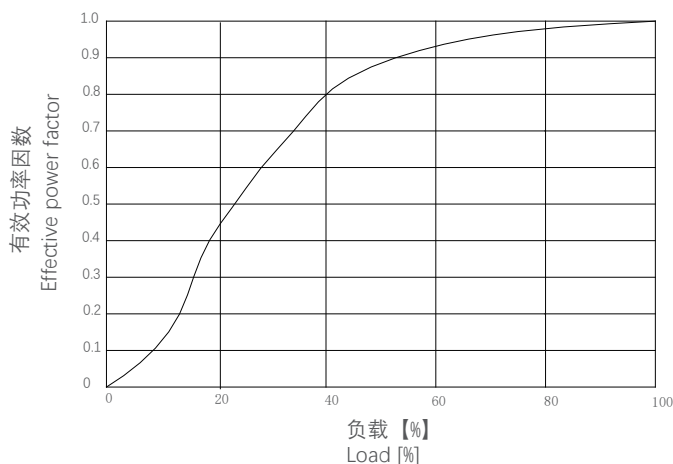
If the application requires a high power factor without load and requires a decrease in capacitor current in standby mode, the capacitor connection should be disconnected. The contactor can disconnect the capacitor connection when the load is below 20%.

在发电机供电时的谐波滤波器，在设计中考虑电容性电流也非常重要。在无负载和低负载情况下，电容性电流可使发电机过励磁。过励磁可导致电压升高，超过HFR和变频器的允许电压。因此，在发电机应用中务必断开电容器连接并认真考虑设计。

It is also important to consider capacitive current in the design of harmonic filters for generator power supply. Under no-load and low load conditions, capacitive current can cause overexcitation of the generator. Overexcitation can cause voltage to increase beyond the allowable voltage of HFR and frequency converter. Therefore, in generator applications, it is essential to disconnect the capacitor connection and carefully consider the design.

在背景失真和供电不平衡的方面，无源谐波滤波器的性能（如HFR）优于多脉冲整流器。然而考虑在部分负载和功率因素场合时，无源滤波器性能差有源滤波器。有关提供的各种谐波改善解决方案的性能定位，请查阅相关谐波改善资料。

In terms of background distortion and power supply imbalance, the performance of passive harmonic filters (such as HFR) is superior to that of multi pulse rectifiers. However, when considering partial loads and power factors, passive filters have poor performance compared to active filters. For performance positioning of various harmonic improvement solutions provided, please refer to relevant harmonic improvement materials.

4. 谐波滤波器选择

Selection of harmonic filters

本章节提供有关如何选择正确尺寸滤波器的指导，包括计算示例，电气数据以及滤波器一般说明。

This chapter provides guidance on how to choose the correct size filter, including calculation examples, electrical data, and general instructions for the filter.

4.1 如何选择正确的HFR

How to choose the right HFR

为了获得最佳的性能，HFR的大小应符合变频器的主电源输入电流。这是依据变频器预期负载（而非变频器本身大小）确定的输入电流。

To achieve optimal performance, the size of HFR should match the input current of the main power supply of the frequency converter. This is the input current determined based on the expected load of the frequency converter (rather than the size of the frequency converter itself).

4.1.1 滤波器电流计算

Filter current calculation

根据电动机铭牌上电动机额定电流 (IM,N) 和电动机功率因数 (COS) 计算变频器的电源输入电流 (IFCL) 如果电机额定电压 (UM,N) 不等于实际电源电压 (UL) 则必须以下等式中所示的这些电压间的比例对计算所得的电流进行校正:

According to the rated current (IM, N) and power factor (COS) of the motor on the motor nameplate. Calculate the power input current (IFCL) of the frequency converter. If the rated motor voltage (UM, N) is not equal to the actual power supply voltage (UL), the calculated current must be corrected by the ratio of these voltages shown in the following equation:

$$I_{FC,L} = 1.1 \times I_{M,N} \times \text{COS} \times \frac{U_{M,N}}{U_L}$$

所选HFR的额定电流(IHFR,N)值必须具有大于或等于计算所得变频器电源输入电流 (IFC.L)。

The rated current (IHFR, N) value of the selected HFR must be greater than or equal to the calculated input current of the inverter power supply (IFC, L).

提示:

由于在滤波器额定负载时，获得最佳谐波性能。使用过大的滤波器功率时，有可能降低THDi性能。

Tip:

Due to achieving optimal harmonic performance at the rated load of the filter. When using excessive filter power, it is possible to reduce THDi performance.

如果必须将几个变频器连接到相同的过滤器上,则必须根据计算所得的电源输入电流总和选用HFR的功率。

If several frequency converters must be connected to the same filter, the power of HFR must be selected based on the calculated total power input current.

如果HFR大小为特定负载且已更换电机,则必须重新计算电流,以避免HFR过载。

If the HFR size is a specific load and the motor has been replaced, the current must be recalculated to avoid HFR overload.

4.1.2 计算实例

Calculation Examples

系统电源电压System power supply voltage(UL): 380V

电机铭牌功率Motor nameplate power(PM): 55KW

电机功率power (η_m) : 0.96

FC功率(η_{FC}) : 0.97

HFR效率(η_{HFR})(最坏情况估计): 0.98

最大线路电流Maximum line current(RMS):

$$\frac{P_M \times 1000}{U_L \times \eta_{FC} \times \eta_{AHF} \times \sqrt{3}} = \frac{55 \times 1000}{380 \times 0.96 \times 0.97 \times 0.98 \times \sqrt{3}} = 91.57A$$

在此种情况下,必须选择96A滤波器。

In this case, a 96A filter must be selected.

4.1.3 电压升压

Voltage boost

在待机和低负载条件下,HFR会提高输入电压值的5%。这意味着，变频器端子电压比滤波器输入时的电压高5%。应在安装设计时考虑此种情况。在690V应用中应特别注意，如果将变频器电压容差降低5%，则在低负载和待机情况下可通过断开电容器连接以限制升高电压。欲了解更多信息，请参阅第6.1节。

Under standby and low load conditions, HFR will increase the input voltage by 5%. This means that the terminal voltage of the frequency converter is 5% higher than the input voltage of the filter. This situation should be considered during installation design. Special attention should be paid in 690V applications. If the voltage tolerance of the frequency converter is reduced by 5%, the voltage increase can be limited by disconnecting the capacitor connection under low load and standby conditions. For more information, please refer to section 6.2.2.

4.2 型号标签

Model label

HOWCORE

谐波滤波器

HARMONIC FILTER

HFR005X4SA037C06

额定容量Capacity: 37KW	
额定电压Cated voltage: 380~400V	
额定频率Frequency: 50HZ	
绝缘电压Insulation voltage: 3000V	
IP:IP20	
重量Weight: 80KG	
生产日期Producing date: 2026年1月12日	

SN:



HK-HFR260112001

上海鸿康电器有限公司
 地址: 上海市松江区沈砖公路3129号13号楼
 电话: 021-37701209,37701219
 手机: 南区 13501656682何经理 北区13818298192 戚经理
 网址: www.howcore.com
 Shanghai Howcore Electric Co., Ltd.
 Address: Building 13, No. 3129, Shenzhuan Road Songjiang District, Shanghai
 Tel: 021-37701209,37701219
 Mobile: Southern District: 13501656682 Manager He Northern District: 13818298192 Manager Qi
 Website: www.howcore.com



4.2.1 谐波电流表现曲线图

Harmonic Current Performance Curve Graph

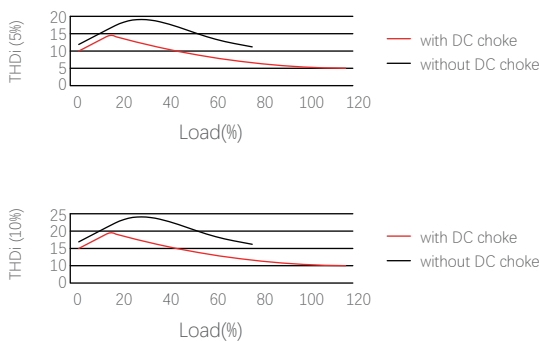

谐波滤波器的性能针对带有直流链路扼流圈的整流器/电机驱动器进行了优化。在此类应用中，预计总谐波失真（THDI）约为5%。强烈建议使用直流链路扼流圈。在没有LDC的系统中，滤波器模块的额定功率必须降低至其标称额定功率的70%以下。在此类应用中，预计总谐波失真（THDI）为10%至15%。

harmonic filter performance is optimized for rectifiers/motor drives with a dc-link choke. In such applications, a THDI of roughly 5% can be expected. The use of a dc-link choke is highly recommended. In a system without LDC, the filter module has to be derated to max. 70% of its nominal power rating. In such applications, a THDI of 10~15% can be expected.

在满负荷运行时，谐波滤波器的功率因数为1。当负载降低时，调谐电路中的功率电容器会因电容电流作用产生超前位移功率因数。所有采用大容量电容器的无源滤波器都存在这一特性。但相较于传统滤波器，Howcore的谐波滤波器适用范围显著扩展（在35%至100%额定负载范围内，功率因数始终维持在0.9以上）。该滤波器支持在轻载状态下断开调谐电路，必要时可避免低DPF情况。安装人员可通过选用与调谐电路匹配的电容器接触器来实现这一功能。

At full load, Harmonic filters yield unity power factor. At lower load levels, the capacitive current into the power capacitors of the trap circuit cause a leading displacement power factor. This is the case with all types of passive filters with large capacitors. However, compared to traditional filters the useful range of Schaffner ecosine is much extended (cos phi >0.9 from 35 to 100% of rated load). Harmonic filters allow for trap disconnect at light load to avoid low DPF situations if required. This feature can be provided by the installer using a capacitor contactor of suitable size for the trap circuit.

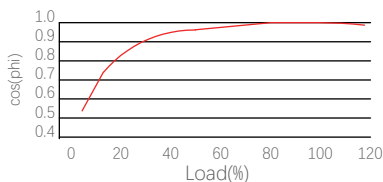

位移功率因数曲线

当负荷大于40%时，功率因数PF大于0.9

当负荷小于20%时，可以断开电容以提高功率因数

Displacement power factor curve

When the load exceeds 40%, the power factor PF is greater than 0.9

When the load is less than 20%, the capacitor can be disconnected to improve the power factor

4.2.2 成品识别码 Product Identification Code

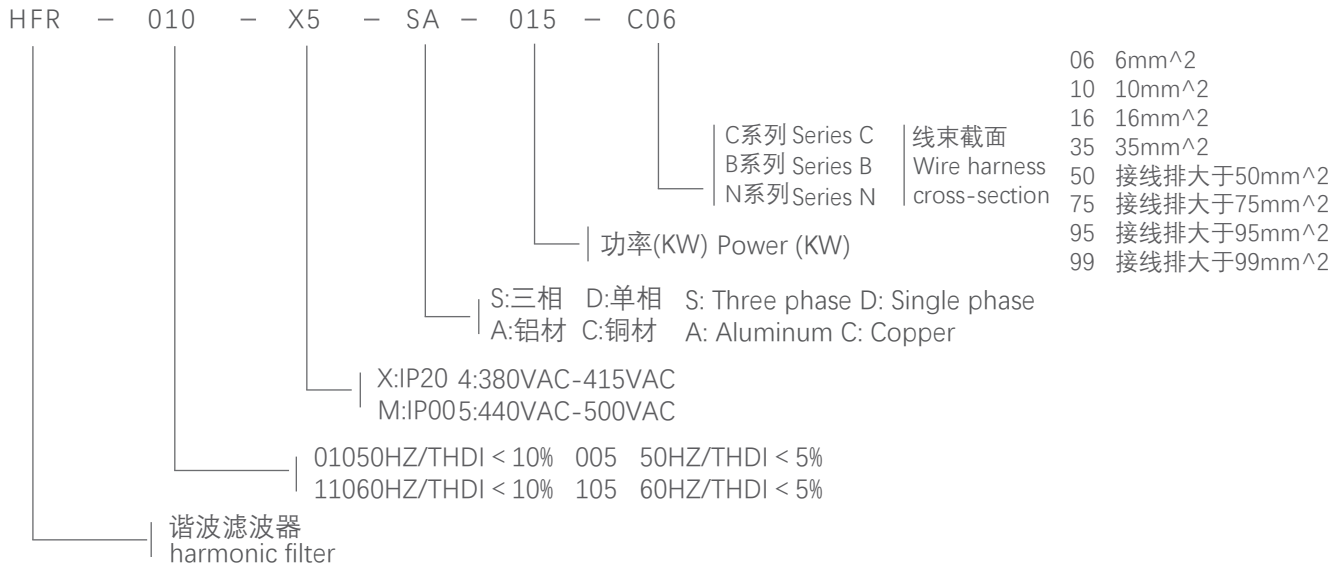

4.3 电气数据

Electrical data

无源系列类别目录 Passive series category catalog

电压系统 (V) ±10%	频率 (Hz)	总谐波电流失真 THID	IP 等级	功率范围 (kW)	效率	冷却方式	过载能力	产品无故障时间 MTBF	电流总需量畸变系数 TDD	环境温度范围	短路电流额定值 SCCR	接地系统	超电压类别
380-415	50±1Hz	≤5%@额定功率	IP20	0.4	> 98%	AN	1.6 倍额定电流 可维持 1 分钟 每小时 一次	>200,000 小时	根据 IEEE-519 标准	-25°C 到 +45°C 可正常运行 +45°C 到 +70°C 需要降低额定值 -25°C 到 +85°C 运输和储藏	100 kA	TN, TT, IT	OV III (IEC 60664-1 / UL 61800-5-1)
	50±1Hz	≤5%@额定功率	IP00										
	50±1Hz	≤10%@额定功率	IP20										
	50±1Hz	≤5%@额定功率	IP20										
440-500	50±1Hz	≤5%@额定功率	IP00	355	> 98%	AN	1.6 倍额定电流 可维持 1 分钟 每小时 一次	>200,000 小时	根据 IEEE-519 标准	-25°C 到 +45°C 可正常运行 +45°C 到 +70°C 需要降低额定值 -25°C 到 +85°C 运输和储藏	100 kA	TN, TT, IT	OV III (IEC 60664-1 / UL 61800-5-1)
	50±1Hz	≤5%@额定功率	IP00										
	50±1Hz	≤10%@额定功率	IP20										
	50±1Hz	≤10%@额定功率	IP20										

4.4 一般说明

Generally speaking

4.4.1 一般技术数据

General technical data

电源容差 Power tolerance	±10%
电源频率容差 Power frequency tolerance	±5%/-1.5%
过载能力 Overload capacity	160%,60S
效率 Efficiency	>0.98
THDI	HFR005 ≤ 5% HFR010 ≤ 10%
IL的COS	10% IHFR,N时为0.5 Cap 50% IHFR,N时为0.8 Cap 75% IHFR,N时为0.85 Cap 100% IHFR,N时为0.99 Cap 160%IHFR,N时为1.00 Cap
功率降容 Power reduction	温度—请参阅以下递减曲线。1000M 海拔高度 <h<2000m=1000m5%

4.4.2 环境数据

Environmental data

周围环境 surrounding environment	
满负荷运转期间的环境温度 Environmental temperature during full load operation	5°C…+45°C -不降容 45°C…+60°C -降容
存放/运输期间的温度 Temperature during storage/transportation	-25°C…+65°C -运输 -25°C…+55°C -存放
最大海拔高度 Maximum altitude	< 1000m (不降容) 1000m -2000m (降容)
最大相对湿度 Maximum relative humidity	温度等级F, 无冷凝5%-85% 运行期间, 等级3K3 (无冷凝)
绝缘强度 Dielectric Strength	过电压类别III符合 ENG61800-5-1
包装 Package	DIN55468 运输包装材料

提示

Prompt

在这些条件下，将变频器的电源电流的THiD降低至10%或5%(额定负载下的典型数值)。在不符合这些条件或仅部分符合这些条件的情况下，虽然可使谐波明显减小，但不会达到THiD额定值。低谐波电流放射降低为THiD表示非影响电源电压的THvD低于2%且短路功率与已安装负载比 (RSCE) 至少为66。

Under these conditions, reduce the THiD of the power supply current of the frequency converterto 10% or 5% (typical value at rated load). In cases where these conditions are not met or only partially met, although harmonics can be significantly reduced, they will not reach the THiD rated value. The low harmonic current emission is reduced to THiD, indicating that the THvD that does not affect the power supply voltage is less than 2% and the short-circuit power to installed load ratio (RSCE) is at least 66.



图4.1性能随温度变化关系
Performance versus temperature variation relationship

5 如何安装 How to install

5.1 机械安装 Mechanical installation

5.1.1 机械安装安全要求 Safety requirements for mechanical installation

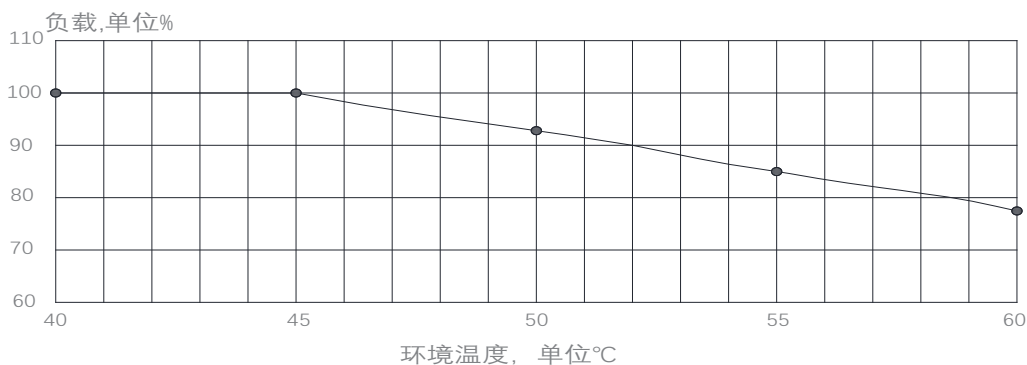
提示

Prompt

请遵照滤波器重量使用正确的吊装设备。

Please use the correct lifting equipment according to the weight of the filter.

提示

Prompt

安装滤波器时，使用两侧的吊环装滤波器。

When installing the filter, use the lifting rings on both sides to install the filter.

提示

Prompt

切勿使用其他部件（端子，外壳等）吊装。

Do not use other components (terminals, casings, etc.) for lifting.

5.1.2 安装 Installation

滤波器安装过程中必须遵照以下指导。

The following guidelines must be followed during the installation process of the filter.

· 必须使用底部端子垂直安装所有滤波器。

All filters must be installed vertically using the bottom terminal.

· 切勿将滤波器安装在其他加热元件附近或加热敏感材料（如木材）附近。

Do not install the filter near other heating elements or heating sensitive materials (such as wood).

· 顶部和底部见间隙至少为150MM。

The gap between the top and bottom should be at least 150mm.

· IP20滤波器表面温度不得超过70度。

The surface temperature of the IP20 filter shall not exceed 70 degrees Celsius.

· 滤波器可与变频器一起并排安装，且对其间隔没有要求。

The filter can be installed side by side with the frequency converter, and there is no requirement for its spacing.

5.1.3 工业外壳安装建议

Industrial Housing Installation Recommendations

为避免高频噪音耦合，在如下方面保持150MM（5.91英寸）的最小距离。

To avoid high-frequency noise coupling, maintain a minimum distance of 150MM (5.91 inches) in the following areas.

- 主电源线

Main power cord

- 机电缆

Motor cable

- 控制线和信号线（电压范围<48V）

Control and signal lines (voltage range<48V)

为获得低阻抗HF连接，接地，屏蔽和其他金属连接（如安装板，安装装置）应具有与金属接地差不多的表面。使用最小10mm²横截面的接地和电位均衡线或更厚的接地胶带。只能使用黄铜或镀锡铜屏蔽线，这是因为钢屏蔽线不适应于高频应用。用金属夹或金属压盖将屏蔽线连接到平衡杆或PE连接。

To obtain low impedance HF connections, grounding, shielding, and other metal connections (such as mounting plates, mounting devices) should have a surface similar to metal grounding. Use grounding and potential equalization wires with a minimum cross-sectional area of 10mm² or thicker grounding tape. Only brass or tinned copper shielding wires can be used, as steel shielding wires are not suitable for high-frequency applications. Connect the shielding wire to the balance bar or PE connection using a metal clip or metal cover.

电感式开关装置（继电器，磁接触器等）务必配备压敏电阻，RC电路或抑制二极管。

Inductive switching devices (relays, magnetic contactors, etc.) must be equipped with varistors, RC circuits, or suppression diodes.

HFR 谐波滤波器有IP00 和IP20 两种防护等级。IP00 滤波器必须安装在合适的壳体或箱柜里以确保安全。滤波器

冷却方式为自然冷却（IP00）或强制风冷（IP20），请在滤波器周围保持至少200mm 的散热空间。IP20 滤波器可以并排安装。必须确保有足够的新鲜冷却空气以供利用，而且热空气可以自由地从滤波器壳体或箱柜中散出。

HFR harmonic filters have two protection levels: IP00 and IP20. The IP00 filter must be installed in a suitable housing or cabinet to ensure safety. The cooling method for the filter is natural cooling (IP00) or forced air cooling (IP20). Please maintain at least 200mm of heat dissipation space around the filter. IP20 filters can be installed side by side. It is necessary to ensure that there is sufficient fresh cooling air for utilization, and hot air can freely escape from the filter housing or cabinet.

5.1.4 通风

Ventilation

通过空气循环冷却滤波器。因此，需要使空气在滤波器上方和下方自由流动。

Cool the filter through air circulation. Therefore, it is necessary to allow air to flow freely above and below the filter.

将滤波器安装在面板或其他工业外壳内时，必须确定有足够的空气流动滤波器，以降低滤波器和周围元件过热的风险。

Cool the filter through air circulation. Therefore, it is necessary to allow air to flow freely above and below the filter. When installing filters inside panels or other industrial enclosures, it is necessary to ensure sufficient air flow filters to reduce the risk of overheating of the filters and surrounding components.

如将其他热源（如变频器）安装在相同的机箱内，则在测量机箱冷却效果时还需考虑产生的热量。

If other heat sources (such as frequency converters) are installed in the same chassis, the heat generated needs to be considered when measuring the cooling effect of the chassis.

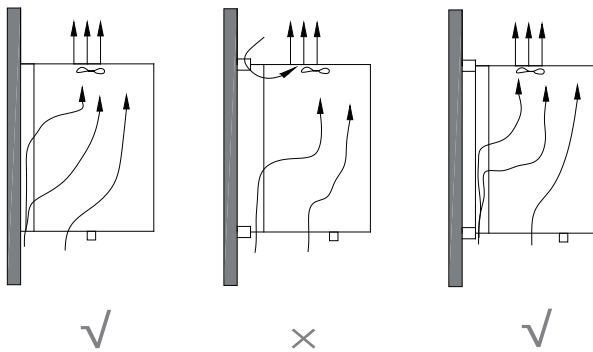

5.2 电器安装

Electrical installation

5.2.1 过温保护

Over temperature protection

谐波滤波器HFR005都配备了在正常温度运行条件下常闭的温控开关（PELV），过滤器过温时断开。

The harmonic filter HFR005 is equipped with a normally closed temperature control switch (PELV) under normal temperature operating conditions, which opens when the filter is overheated.

提示

prompt

使用过温保护，以防过温造成滤波器损坏。必须在30秒（最长）内及时停止或控制减速，以防损坏滤波器。

Use over temperature protection to prevent damage to the filter caused by over temperature. It is necessary to stop or control deceleration in a timely manner within 30 seconds (maximum) to prevent damage to the filter.

有多种方法。可使用开关，一个示例就是将谐波滤波器端子TH1连接到变频器的端子12或13（电压供电数字输入，24V），将端子TH2连接到端子27。将数字输入端子27编程为惯性停止。变频器将使电机自由停止，从而在检测到过温情况时卸下滤波器。或者，使用端子12、33并设置1-90电机热保。

There are multiple methods. A switch can be used, an example is to connect terminal TH1 of the harmonic filter to terminal 12 or 13 of the frequency converter (voltage powered digital input, 24V), and connect terminal TH2 to terminal 27. Program the digital input terminal 27 to inertia stop. The frequency converter will allow the motor to stop freely, thereby removing the filter when an over temperature situation is detected. Alternatively, use terminals 12 and 33 and set 1-90 motor thermal protection.

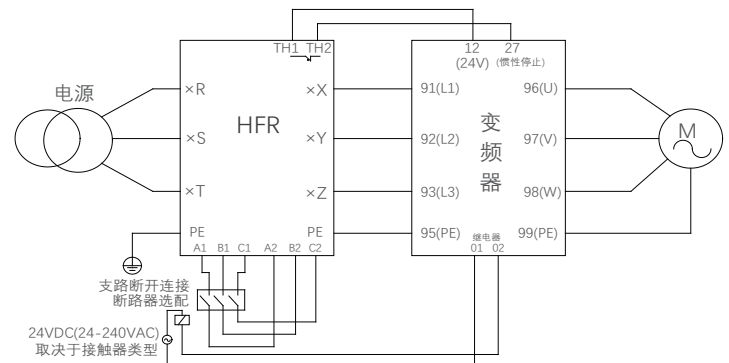

提示

prompt

过温接触器最大额定值为250VAC和10A

The maximum rated value of the over temperature contactor is 250VAC and 10A

5.2.2 电容器断开连接接触器

Capacitor disconnection contactor

谐波滤波器HFR005的功率因数负载的降低而降低。在无负载的情况下，功率因数为0，电容器可产生约为滤波器额定电流25%的超前无功电流。在无功电流不可接受的应用情况下，可将端子XA1, XB1, XC1和XA2, XB2, XC2上的电容器组断开。

The power factor of harmonic filter HFR005 decreases with the decrease of load. Under no load, with a power factor of 0, the capacitor can generate a leading reactive current of approximately 25% of the rated current of the filter. In applications where reactive current is unacceptable, the capacitor banks on terminals XA1, XB1, XC1 and XA2, XB2, XC2 can be disconnected.

默认（交付）时带XA1和XA2, XB1和XB2以及C1和XC2是短接的。

By default (delivery), XA1 and XA2, XB1 and XB2, as well as C1 and XC2 are short circuited.

如需断开电容器的连接，则应将三相接触器置于端子XA1, XB1, XC1和XA2, XB2, XC2之间。建议使用AC3接触器。

If it is necessary to disconnect the capacitor, the three-phase contactor should be placed between terminals XA1, XB1, XC1 and XA2, XB2, XC2. It is recommended to use AC3 contactors.

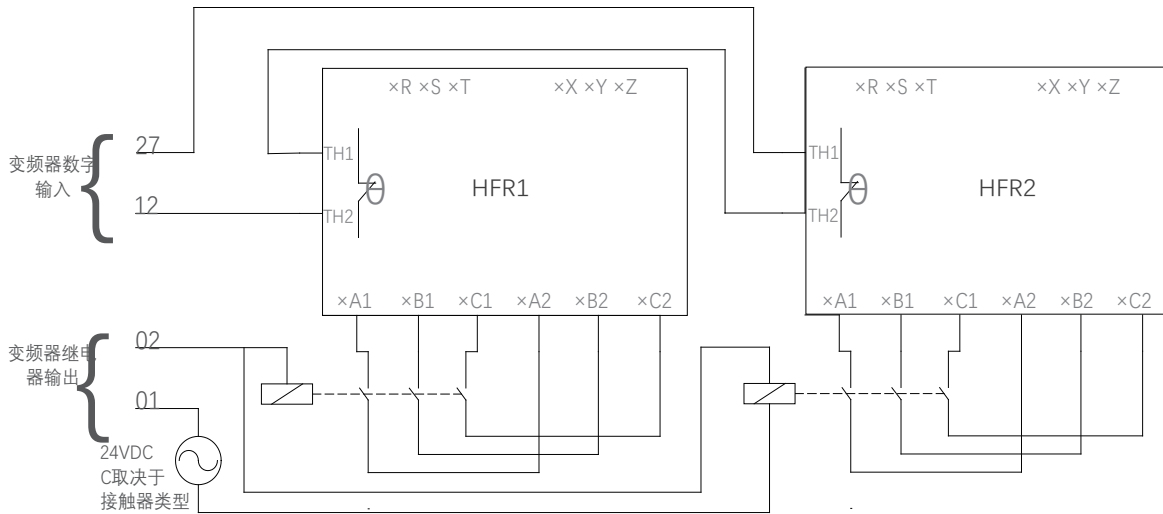

提示

prompt

不允许将一个公用3极接触器与几个平行高级谐波滤波器一起使用。

It is not allowed to use a common 3-pole contactor with several parallel advanced harmonic filters.

未断开电容器连接时，待机以及低负载状况下的HFR滤波器会将输入电压最高提升至5%，即滤波器的输出端电压降高于输入端电压5%。应在安装设计时考虑此种情况。在待机以及低负载状况下断开电容器连接时很好的选择。

When the capacitor connection is not disconnected, the HFR filter in standby and low load conditions will increase the input voltage up to 5%, that is, the output voltage drop of the filter is 5% higher than the input voltage. This situation should be considered during installation design. It is a good choice to disconnect the capacitor connection in standby and low load conditions.

只能在低于20%输出功率时切换接触器。重新连接前，允许电容器放电至少25秒。

The contactor can only be switched when the output power is below 20%. Before reconnecting, allow the capacitor to discharge for at least 25 seconds.

5.2.3 连接示意图

connection diagram

谐波滤波器是抑制传动输入侧高频谐波电流的低通滤波器。下图显示了有谐波滤波器的传动系统。

A harmonic filter is a low-pass filter that suppresses high-frequency harmonic currents on the input side of the transmission. The following figure shows a transmission system with a harmonic filter.

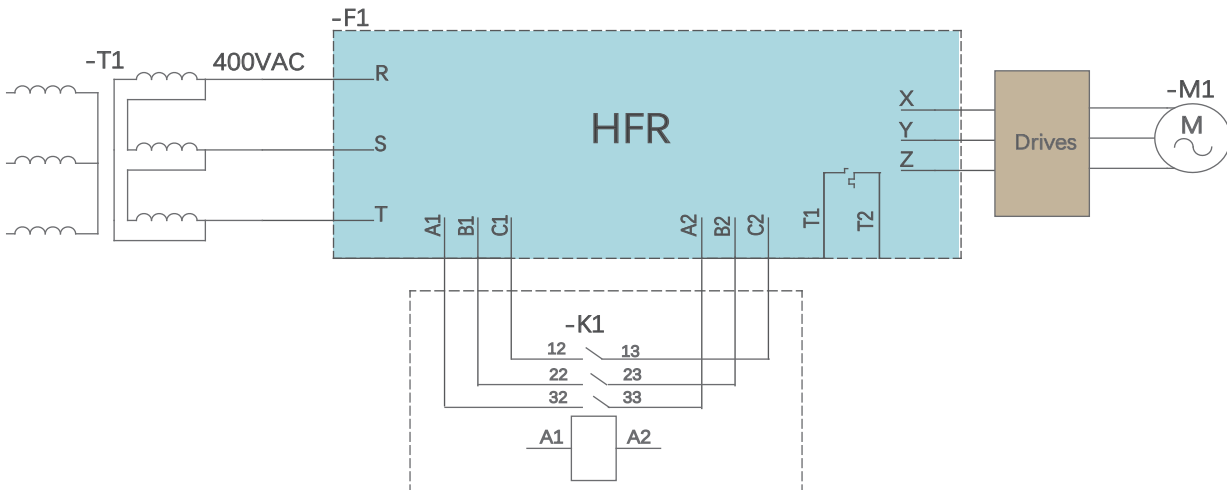

5.2.4 电气原理图
Schematic Diagram

下图显示了谐波滤波器的电气原理图。
The following diagram shows the electrical schematic of the harmonic filter.

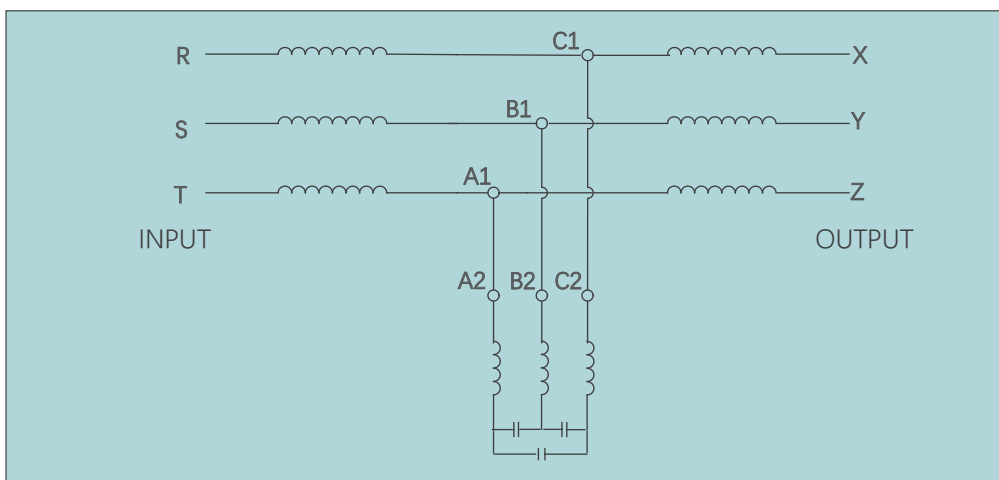

5.2.5 电气连接
Electrical connections

N系列 N Series

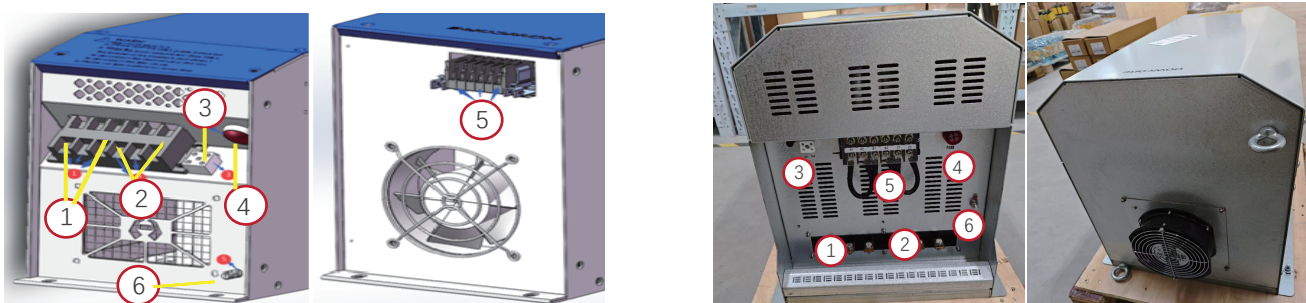

B系列 B Series

C系列 C Series

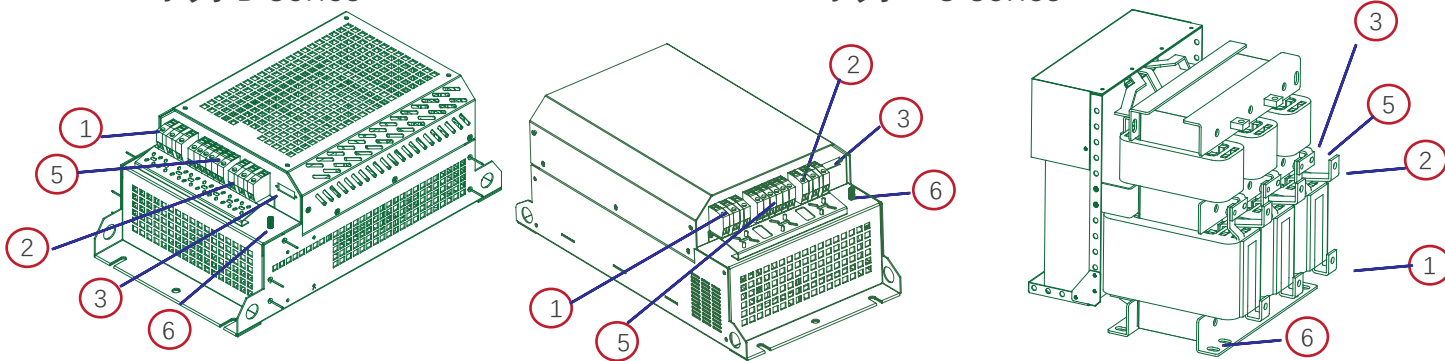

序号	端子编号 terminal number	描述 description
1	R/S/T	HFR滤波器输入端子 HFR filter input terminal
2	X/Y/Z	HFR滤波器输出端子 HFR filter output terminal
3	TH1/TH2	过热保护开关端子 145°C NC开关 <small>Overheat protection switch terminal, 145°C, NC switch</small>
4		过热蜂鸣报警器 Overheat buzzer alarm
5	A1-A2/B1-B2/C1-C2	HFR滤波器回路端子 (外部接触器控制) <small>HFR filter circuit terminal (controlled by external contactor)</small>
6		保护接地 Protective Earthing

- * 针对需要将滤波支路旁路的使用方式，将A1-A2, B1-B2, C1-C2 之间的短接线拆除后，用户根据选型信息里的filter 电流值选择合适的控制接触器。
For the use of filtering branch bypass, after removing the short circuit between A1-A2, B1-B2, C1-C2 the user selects the appropriate control contactor based on the filter current value in the selection information.

5.2.6 布线

Wiring

必须将电源线接到端子R, S, 和 T。变频器供电端子L1, L2和L3必须连接到滤波器端子X, Y, 和Z。
The power cord must be connected to terminals R, S, and T. The power supply terminals L1, L2, and L3 of the frequency converter must be connected to the filter terminals X, Y, and Z.

变频器并联

Parallel connection of frequency converters

将几个变频器连接到一个滤波器上的情况下，连接方法与上述连接类似。变频器的电源端子L1, L2, 和L3必须连接到滤波器端子X, Y和Z上。

When connecting several frequency converters to a filter, the connection method is similar to the above. The power terminals L1, L2, and L3 of the frequency converter must be connected to the filter terminals X, Y, and Z.

提示

Prompt

按照当地法规使用电缆。

Use cables in accordance with local regulations.

并联滤波器

Parallel filter

如果变频器的电源输入电流超过最大谐波滤波器的额定电流，则可将几个谐波滤波器并联，以达到必需的电流额定值—请参阅电气数据表。

If the power input current of the frequency converter exceeds the rated current of the maximum harmonic filter, several harmonic filters can be connected in parallel to achieve the necessary current rating - please refer to the electrical data sheet.

必须连接到滤波器端子R,S和T的电源电压。变频器的电源端子L1,L2和L3必须连接到滤波器端子X,Y和Z上。

It must be connected to the power supply voltage of filter terminals R,S, and T. The power terminals L1, L2, and L3 of the frequency converter must be connected to the filter terminals X,Y and Z.

谐波滤波器C系列 380-415V-50Hz-5%-IP20 Harmonic filter C series 380-415V-50Hz-5%-IP20

谐波滤波器型号 Harmonic filter type	额定负荷功率 [kW] Rated load power	电机驱动输入 电流 [Arms] Motor drive input current	额定滤波器输入 电流[Arms] Rated filter input current	净重 [kg] Net weight	毛重 [kg] Gross weight	典型损耗 [W] Typical loss	适配电缆 [m ²] Adapter cable	机型 model
HFR005X4SC001C06	0.4-1.5	1-3.7	0.5-2.2	10	17.5	29.5	06	H1
HFR005X4SC002C06	2.2	5.5	3.28	14.5	21.75	45	06	H1
HFR005X4SC005C06	3.7-5.5	10-13	8.2	20	30	75	06	H1
HFR005X4SC007C06	7.5	16	11.2	26	39	100	06	H1
HFR005X4SA011C10	11	24	16.5	35	52.5	125	10	H1
HFR005X4SA015C10	15	30	22.5	45	67.5	225	10	H2
HFR005X4SA022C16	18.5-22	44	32.5	52	78	300	16	H2
HFR005X4SA030C16	30	60	44.5	63	94.5	360	16	H3
HFR005X4SA037C35	37	75	54.8	70	105	420	35	H3
HFR005X4SA045C35	45	90	66.8	88	132	470	35	H3
HFR005X4SA055C50	55	110	81.8	103	154.5	560	50	H3
HFR005X4SA075C99	75	150	111	118	177	750	99	H4
HFR005X4SA090C99	90	180	134	135	202.5	850	99	H4
HFR005X4SA110C99	110	210	164	158	237	950	99	H4
HFR005X4SA132C99	132	260	197	245.8	318.7	1050	99	H5
HFR005X4SA160C99	160	320	240	328.5	492.75	1300	99	H5

谐波滤波器C系列 380-415V-50Hz-5%-IP00 Harmonic filter C series 380-415V-50Hz-5%-IP00

谐波滤波器型号 Harmonic filter type	额定负荷功率 [kW] Rated load power	电机驱动输入 电流 [Arms] Motor drive input current	额定滤波器输入 电流[Arms] Rated filter input current	重量 [kg] weight	毛重 [kg] Gross weight	典型损耗 [W] Typical loss	适配电缆 [m ²] Adapter cable	机型 model
HFR005M4SA075C99	75	150	111	118	177	750	99	H6
HFR005M4SA090C99	90	180	134	135	202.5	850	99	H6
HFR005M4SA110C99	110	210	164	158	237	950	99	H6
HFR005M4SA132C99	132	260	197	245.8	318.7	1050	99	H7
HFR005M4SA160C99	160	320	240	328.5	492.75	1300	99	H7
HFR005M4SA200C99	185-200	400	296	373	559.5	1500	99	H8
HFR005M4SA250C99	220-250	480	356	418.5	627.75	1750	99	H9
HFR005M4SA315C99	285-315	600	444	450	675	2150	99	H10
HFR005M4SA355C99	355	670	500	500	750	2350	99	H11

谐波滤波器C系列 380-415V-50Hz-10%-IP20 Harmonic filter C series 380-415V-50Hz-10%-IP20

谐波滤波器型号 Harmonic filter type	额定负荷功率 [kW] Rated load power	电机驱动输入 电流 [Arms] Motor drive input current	额定滤波器输入 电流[Arms] Rated filter input current	重量 [kg] weight	毛重 [kg] Gross weight	典型损耗 [W] Typical loss	适配电缆 [m ²] Adapter cable	机型 model
HFR010X4SC001C06	0.4-1.5	1-3.7	0.5-2.2	10	17.5	29.5	06	H1
HFR010X4SC002C06	2.2	5.5	3.28	13	19.5	40.5	06	H1
HFR010X4SC005C06	3.7-5.5	10-13	8.2	18	27	67.5	06	H1
HFR010X4SC007C06	7.5	16	11.2	23.4	35.1	90	06	H1
HFR010X4SA011C10	11	24	16.5	31.5	47.25	112.5	10	H1
HFR010X4SA015C10	15	30	22.5	40.5	60.75	202.5	10	H2
HFR010X4SA022C16	18.5-22	44	32.5	46.8	70.2	270	16	H2
HFR010X4SA030C16	30	60	44.5	56.7	85.05	324	16	H3
HFR010X4SA037C35	37	75	54.8	63	94.5	378	35	H3
HFR010X4SA045C35	45	90	66.8	79.2	118.8	423	35	H3
HFR010X4SA055C50	55	110	81.8	92.7	139.05	504	50	H3
HFR010X4SA075C99	75	150	111	106.2	159.3	675	99	H4
HFR010X4SA090C99	90	180	134	135	202.5	765	99	H4
HFR010X4SA110C99	110	210	164	142.3	213.45	855	99	H4
HFR010X4SA132C99	132	260	197	245.8	318.7	1050	99	H5
HFR010X4SA160C99	160	320	240	328.5	492.75	1300	99	H5

谐波滤波器C系列 380-415V-50Hz-10%-IP00

Harmonic filter C series 380-415V-50Hz-10%-IP00

谐波滤波器型号 Harmonic filter type	额定负荷功率 [kW] Rated load power	电机驱动输入 电流 [Arms] Motor drive input current	额定滤波器输入 电流[Arms] Rated filter input current	净重 [kg] Net weight	毛重 [kg] Gross weight	典型损耗 [W] Typical loss	适配电缆 [m ²] Adapter cable	机型 model
HFR010M4SA075C99	75	150	111	106.2	159.3	675	99	H6
HFR010M4SA090C99	90	180	134	135	202.5	765	99	H6
HFR010M4SA110C99	110	210	164	142.3	213.45	855	99	H6
HFR010M4SA132C99	132	260	197	245.8	318.7	1050	99	H7
HFR010M4SA160C99	160	320	240	328.5	492.75	1300	99	H7
HFR010M4SA200C99	185-200	400	296	373	559.5	1500	99	H8
HFR010M4SA250C99	220-250	480	356	418.5	627.75	1750	99	H9
HFR010M4SA315C99	285-315	600	444	450	675	2150	99	H10
HFR010M4SA355C99	355	670	500	500	750	2350	99	H11

谐波滤波器C系列 440-500V-50Hz-5%-IP20

Harmonic filter C series 440-500V-50Hz-5%-IP20

谐波滤波器型号 Harmonic filter type	额定负荷功率 [kW] Rated load power	净重 [kg] Net weight	毛重 [kg] Gross weight	典型损耗 @25°C/50Hz [W] Typical loss	适配电缆 [m ²] Adapter cable	机型 model
HFR005X5SC001C06	0.4-1.5	10	17.5	29.5	06	H1
HFR005X5SC002C06	2.2	14.5	21.75	45	06	H1
HFR005X5SC004C06	3.7	18.5	27.75	68	06	H1
HFR005X5SC005C06	5.5	20	30	75	06	H1
HFR005X5SC007C06	7.5	26	39	100	06	H1
HFR005X5SA011C06	11	35	52.5	125	06	H1
HFR005X5SA015C06	15	45	67.5	225	06	H2
HFR005X5SA022C10	18.5-22	52	78	300	10	H2
HFR005X5SA030C10	30	63	94.5	360	10	H3
HFR005X5SA037C10	37	70	105	420	10	H3
HFR005X5SA045C16	45	88	132	470	16	H3
HFR005X5SA055C35	55	103	154.5	560	35	H3
HFR005X5SA075C35	75	118	177	750	35	H4
HFR005X5SA090C50	90	135	202.5	850	50	H4
HFR005X5SA110C50	110	158	237	950	50	H4
HFR005X5SA132C75	132	245.8	318.7	1050	75	H5
HFR005X5SA160C95	160	328.5	492.75	1300	95	H5

谐波滤波器C系列 440-500V-50Hz-5%-IP00

Harmonic filter C series 440-500V-50Hz-5%-IP00

谐波滤波器型号 Harmonic filter type	额定负荷功率 [kW] Rated load power	净重 [kg] Net weight	毛重 [kg] Gross weight	典型损耗 @25°C/50Hz [W] Typical loss	适配电缆 [m ²] Adapter cable	机型 model
HFR005M5SA075C35	75	118	177	750	35	H6
HFR005M5SA090C50	90	135	202.5	850	50	H6
HFR005M5SA110C50	110	158	237	950	50	H6
HFR005M5SA132C75	132	245.8	318.7	1050	75	H7
HFR005M5SA160C95	160	328.5	492.75	1300	95	H7
HFR005M5SA200C99	185-200	373	559.5	1500	99	H8
HFR005M5SA250C99	220-250	418.5	627.75	1750	99	H9
HFR005M5SA315C99	285-315	480	720	2000	99	H10
HFR005M5SA355C99	355-385	520	780	2500	99	H11

谐波滤波器C系列 440-500V-50Hz-10%-IP20

Harmonic filter C series 440-500V-50Hz-10%-IP20

谐波滤波器型号 Harmonic filter type	额定负荷功率 [kW] Rated load power	净重 [kg] Net weight	毛重 [kg] Gross weight	典型损耗 @25°C/50Hz [W] Typical loss	适配电缆 [m ²] Adapter cable	机型 model
HFR010X5SC001C06	0.4-1.5	10	17.5	29.5	06	H1
HFR010X5SC002C06	2.2	14.5	21.75	45	06	H1
HFR010X5SC004C06	4.5	16.5	24.75	62.5	06	H1
HFR010X5SC005C06	5.5	18	27	67.5	06	H1
HFR010X5SC007C06	7.5	23.4	35.1	90	06	H1
HFR010X5SA011C06	11	31.5	47.25	112.5	06	H1
HFR010X5SA015C06	15	40.5	60.75	202.5	06	H2
HFR010X5SA022C10	18.5-22	46.8	70.2	270	10	H2
HFR010X5SA030C10	30	56.7	85.05	324	10	H3
HFR010X5SA037C10	37	63	94.5	378	10	H3
HFR010X5SA045C16	45	79.2	118.8	423	16	H3
HFR010X5SA055C35	55	92.7	139.05	504	35	H3
HFR010X5SA075C35	75	106.2	159.3	675	35	H4
HFR010X5SA090C50	90	12.5	18.75	765	50	H4
HFR010X5SA110C50	110	142.3	213.45	855	50	H4
HFR010X5SA132C75	132	145.8	218.7	1050	75	H5
HFR010X5SA160C95	160	328.5	492.75	1300	95	H5

谐波滤波器C系列 440-500V-50Hz-10%-IP00

Harmonic filter C series 440-500V-50Hz-10%-IP00

谐波滤波器型号 Harmonic filter type	额定负荷功率 [kW] Rated load power	净重 [kg] Net weight	毛重 [kg] Gross weight	典型损耗 @25°C/50Hz [W] Typical loss	适配电缆 [m ²] Adapter cable	机型 model
HFR010M5SA075C35	75	106.2	159.3	675	35	H6
HFR010M5SA090C50	90	12.5	18.75	765	50	H6
HFR010M5SA110C50	110	142.3	213.45	855	50	H6
HFR010M5SA132C75	132	145.8	218.7	1050	75	H7
HFR010M5SA160C95	160	328.5	492.75	1300	95	H7
HFR010M5SA200C99	185-200	373	559.5	1500	99	H8
HFR010M5SA250C99	220-250	418.5	627.75	1750	99	H9
HFR010M5SA315C99	285-315	480	720	2000	99	H10
HFR010M5SA355C99	355-385	520	780	2500	99	H11

谐波滤波器C系列 380-415V-60Hz-5%-IP20

Harmonic filter C series 380-415V-60Hz-5%-IP20

谐波滤波器型号 Harmonic filter type	额定负荷功率 [kW] Rated load power	电机驱动输入 电流[Arms] Motor drive input current	额定滤波器输入 电流[Arms] Rated filter input current	净重 [kg] Net weight	毛重 [kg] Gross weight	典型损耗 [W] Typical loss	适配电缆 [m ²] Adapter cable	机型 model
HFR105X4SC001C06	0.4-1.5	1-3.7	0.5-2.2	10	17	29.5	06	H1
HFR105X4SC002C06	2.2	7	5	14.5	21.75	88	06	H1
HFR105X4SC005C06	3.7-5.5	14	10.5	20	30	115	06	H1
HFR105X4SC007C06	7.5	21	14.4	26	39	185	06	H1
HFR105X4SA011C10	11	27-34	12	35	52.5	225	10	H1
HFR105X4SA015C10	15	44	29	45	67.5	285	10	H2
HFR105X4SA022C16	22	52-66	40	52	78	300	16	H2
HFR105X4SA030C16	30	83	55	63	94.5	450	16	H3
HFR105X4SA037C35	37	103	66	70	105	650	35	H3
HFR105X4SA055C50	55	128	96	103	154.5	850	50	H3
HFR105X4SA075C99	75	165	150	118	177	950	99	H4
HFR105X4SA090C99	90	208	180	135	202.5	1050	99	H4
HFR105X4SA110C99	110	240	217	158	237	1250	99	H4
HFR105X4SA132C99	132	320	259	205	315	1380	99	H5
HFR105X4SA160C99	160	403	290	265	397.5	1540	99	H5

谐波滤波器C系列 380-415V-60Hz-5%-IP00

Harmonic filter C series 380-415V-60Hz-5%-IP00

谐波滤波器型号 Harmonic filter type	额定负荷功率 Rated load power [KW]	电机驱动输入 电流[Arms] Motor drive input current	额定滤波器输入 电流[Arms] Rated filter input current	净重 [kg] Net weight	毛重 [kg] Gross weight	典型损耗 [W] Typical loss	适配电缆 [m ²] Adapter cable	机型 model
HFR105M4SA075C99	75	165	150	118	177	950	99	H6
HFR105M4SA090C99	90	208	180	135	202.5	1050	99	H6
HFR105M4SA110C99	110	240	217	158	237	1250	99	H6
HFR105M4SA132C99	132	320	259	205	315	1380	99	H7
HFR105M4SA160C99	160	403	290	265	397.5	1540	99	H7
HFR105M4SA200C99	200	495	370	305	457.5	1817	99	H8
HFR105M4SA250C99	250	610	520	350	525	2144	99	H9
HFR105M4SA315C99	315	759	580	403	604.5	2530	99	H10
HFR105M4SA355C99	355	820	650	425	637.5	2850	99	H11

谐波滤波器C系列 380-415V-60Hz-10%-IP20

Harmonic filter C series 380-415V-60Hz-10%-IP20

谐波滤波器型号 Harmonic filter type	额定负荷功率 Rated load power [KW]	电机驱动输入 电流[Arms] Motor drive input current	额定滤波器输入 电流[Arms] Rated filter input current	净重 [kg] Net weight	毛重 [kg] Gross weight	典型损耗 [W] Typical loss	适配电缆 [m ²] Adapter cable	机型 model
HFR110X4SC001C06	0.4-1.5	1-3.7	0.5-2.2	10	17	29.5	06	H1
HFR110X4SC002C06	2.2	7	5	12.5	18.75	80	06	H1
HFR110X4SC005C06	3.7-5.5	14	10.5	18	27	105	06	H1
HFR110X4SC007C06	7.5	21	14.4	23.5	35.25	172	06	H1
HFR110X4SA011C10	11	27-34	12	32	48	210	10	H1
HFR110X4SA015C10	15	44	29	41.5	62.25	255	10	H2
HFR110X4SA022C16	22	52-66	40	48.5	72.75	280	16	H2
HFR110X4SA030C16	30	83	55	59	88.5	395	16	H3
HFR110X4SA037C35	37	103	66	65	97.5	580	35	H3
HFR110X4SA055C50	55	128	96	96	144	760	50	H3
HFR110X4SA075C99	75	165	150	108	162	880	99	H4
HFR110X4SA090C99	90	208	180	118	177	965	99	H4
HFR110X4SA110C99	110	240	217	142	213	1050	99	H4
HFR110X4SA132C99	132	320	259	150	225	1380	99	H5
HFR110X4SA160C99	160	403	290	265	397.5	1540	99	H5

谐波滤波器C系列 380-415V-60Hz-10%-IP00

Harmonic filter C series 380-415V-60Hz-10%-IP00

谐波滤波器型号 Harmonic filter type	额定负荷功率 Rated load power [KW]	电机驱动输入 电流[Arms] Motor drive input current	额定滤波器输入 电流[Arms] Rated filter input current	净重 [kg] Net weight	毛重 [kg] Gross weight	典型损耗 [W] Typical loss	适配电缆 [m ²] Adapter cable	机型 model
HFR110M4SA075C99	75	165	150	108	162	880	99	H6
HFR110M4SA090C99	90	208	180	118	177	965	99	H6
HFR110M4SA110C99	110	240	217	142	213	1050	99	H6
HFR110M4SA132C99	132	320	259	150	225	1380	99	H7
HFR110M4SA160C99	160	403	290	265	397.5	1540	99	H7
HFR110M4SA200C99	200	495	370	305	457.5	1817	99	H8
HFR110M4SA250C99	250	610	520	350	525	2144	99	H9
HFR110M4SA315C99	315	759	580	403	604.5	2530	99	H10
HFR110M4SA355C99	355	820	650	425	637.5	2850	99	H11

谐波滤波器C系列 440-500V-60Hz-5%-IP20 Harmonic filter C series 440-500V-60Hz-5%-IP20

谐波滤波器型号 Harmonic filter type	额定负荷功率 Rated load power [KW]	电机驱动输入 电流[Arms] Motor drive input current	额定滤波器输入 电流[Arms] Rated filter input current	净重 [kg] Net weight	毛重 [kg] Gross weight	典型损耗 [W] Typical loss	适配电缆 [m] Adapter cable	机型 model
HFR105X5SC001C06	0.4-1.5	1-3.7	0.5-2.2	10	17	29.5	06	H1
HFR105X5SC002C06	2.2	7	5	14.5	21.75	88	06	H1
HFR105X5SC005C06	3.7-5.5	14	10.5	20	30	115	06	H1
HFR105X5SC007C06	7.5	21	14.4	23	36	165	06	H1
HFR105X5SC011C06	11	27-34	12	26	39	185	06	H1
HFR105X5SC015C06	15	44	29	35	52.5	225	06	H2
HFR105X5SA022C06	22	52-66	40	45	67.5	285	06	H2
HFR105X5SA030C10	30	83	55	52	78	300	10	H3
HFR105X5SA037C10	37	103	66	63	94.5	450	10	H3
HFR105X5SA045C16	45	115	80	70	105	650	16	H3
HFR105X5SA055C35	55	128	96	103	154.5	850	35	H4
HFR105X5SA075C35	75	165	150	118	177	950	35	H4
HFR105X5SA090C50	90	208	180	135	202.5	1050	50	H4
HFR105X5SA110C50	110	240	217	139	208.5	1050	50	H4
HFR105X5SA132C75	132	320	259	175	262.5	1380	75	H5
HFR105X5SA160C95	160	403	290	230	345	1540	95	H5

谐波滤波器C系列 440-500V-60Hz-5%-IP00 Harmonic filter C series 440-500V-60Hz-5%-IP00

谐波滤波器型号 Harmonic filter type	额定负荷功率@ 460 V/60 Hz Rated load power [KW]	电机驱动输入 电流[Arms] Motor drive input current	额定滤波器输入 电流[Arms] Rated filter input current	净重 [kg] Net weight	毛重 [kg] Gross weight	典型损耗 [W] Typical loss	适配电缆 [m] Adapter cable	机型 model
HFR105M5SA075C35	75	165	150	118	177	950	35	H6
HFR105M5SA090C35	90	208	180	135	202.5	1050	35	H6
HFR105M5SA110C75	110	240	217	139	208.5	1050	75	H6
HFR105M5SA132C75	132	320	259	175	262.5	1380	75	H7
HFR105M5SA160C95	160	403	290	230	345	1540	95	H7
HFR105M5SA200C99	200	495	370	260	390	1817	99	H8
HFR105M5SA250C99	250	610	520	315	472.5	2144	99	H9
HFR105M5SA315C99	315	759	580	345	517.5	2530	99	H10
HFR105M5SA355C99	355	820	650	385	577.5	2950	99	H11

谐波滤波器C系列 440-500V-60Hz-10%-IP20 Harmonic filter C series 440-500V-60Hz-10%-IP20

谐波滤波器型号 Harmonic filter type	额定负荷功率@ 460 V/60 Hz Rated load power [KW]	电机驱动输入 电流[Arms] Motor drive input current	额定滤波器输入 电流[Arms] Rated filter input current	净重 [kg] Net weight	毛重 [kg] Gross weight	典型损耗 [W] Typical loss	适配电缆 [m] Adapter cable	机型 model
HFR110X5SC001C06	0.4-1.5	1-3.7	0.5-2.2	10	17	29.5	06	H1
HFR110X5SC004C06	2.2	7	5	14.5	21.75	88	06	H1
HFR110X5SC005C06	3.7-5.5	14	10.5	20	30	115	06	H1
HFR110X5SC007C06	7.5	21	14.4	26	39	135	06	H1
HFR110X5SC011C06	11	27-34	12	28.5	43.75	165	06	H1
HFR110X5SC015C06	15	44	29	32.5	48.75	108	06	H2
HFR110X5SA022C06	22	52-66	40	41	61.5	162	06	H2
HFR110X5SA030C06	30	83	55	47.5	71.25	275	06	H3
HFR110X5SA037C10	37	103	66	58.5	87.75	415	10	H3
HFR110X5SA045C10	45	115	80	66	99	620	10	H3
HFR110X5SA055C10	55	128	96	95	142.5	815	10	H4
HFR110X5SA075C35	75	165	150	106	159	905	35	H4
HFR110X5SA090C50	90	208	180	118	177	980	50	H4
HFR110X5SA110C50	110	240	217	139	208.5	1050	50	H4
HFR110X5SA132C75	132	320	259	175	262.5	1380	75	H5
HFR110X5SA160C95	160	403	290	230	345	1540	95	H5

谐波滤波器型号 Harmonic filter type	额定负荷功率 Rated load power [KW]	电机驱动输入 电流[Arms] Motor drive input current	额定滤波器输入 电流[Arms] Rated filter input current	净重 [kg] Net weight	毛重 [kg] Gross weight	典型损耗 [W] Typical loss	适配电缆 [m ²] Adapter cable	机型 model
HFR110M5SA075C35	75	165	150	106	159	905	35	H6
HFR110M5SA090C50	90	208	180	118	177	980	50	H6
HFR110M5SA110C50	110	240	217	139	208.5	1050	50	H6
HFR110M5SA132C75	132	320	259	175	262.5	1380	75	H7
HFR110M5SA160C95	160	403	290	230	345	1540	95	H7
HFR110M5SA200C99	200	495	370	260	390	1817	99	H8
HFR110M5SA250C99	250	610	520	315	472.5	2144	99	H9
HFR110M5SA315C99	315	759	580	345	517.5	2530	99	H10
HFR110M5SA355C99	355	820	650	385	577.5	2950	99	H11

■ 产品尺寸图 (Product Dimension Drawing)

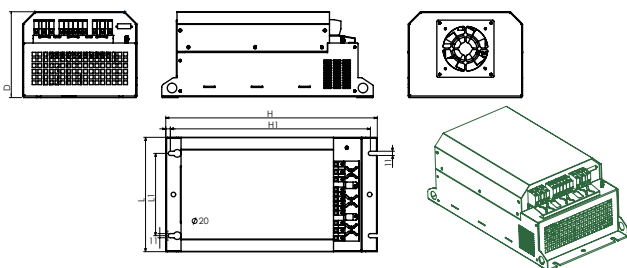

H1/H2/H3

机型 model	尺寸Size (±2mm)					
	L	D	H	L1	H1	A/B
H1	300	230	555	216	525	11*18
H2	410	275	650	350	640	11*15
H3	410	380	700	350	660	11*15

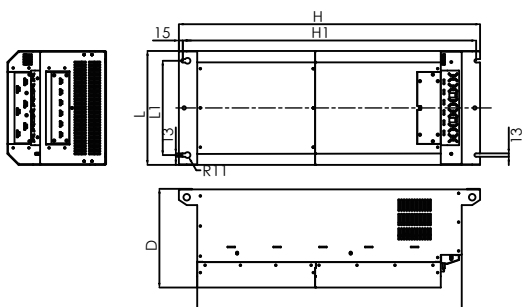

H4

机型 model	尺寸Size (±2mm)					
	L	D	H	L1	H1	A/B
H4	435	377	1150	360	1120	13*20

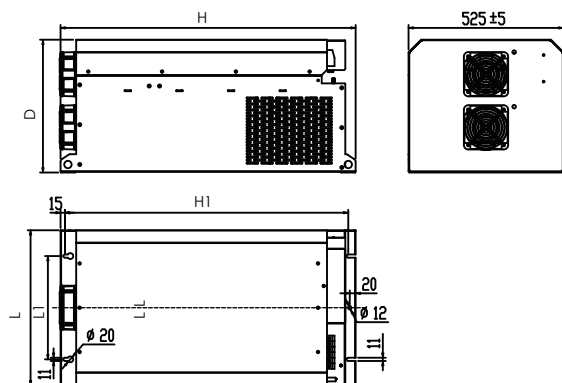

H5

机型 model	尺寸Size (±2mm)					
	L	D	H	L1	H1	A/B
H5	525	450	1000	350	960	11*20

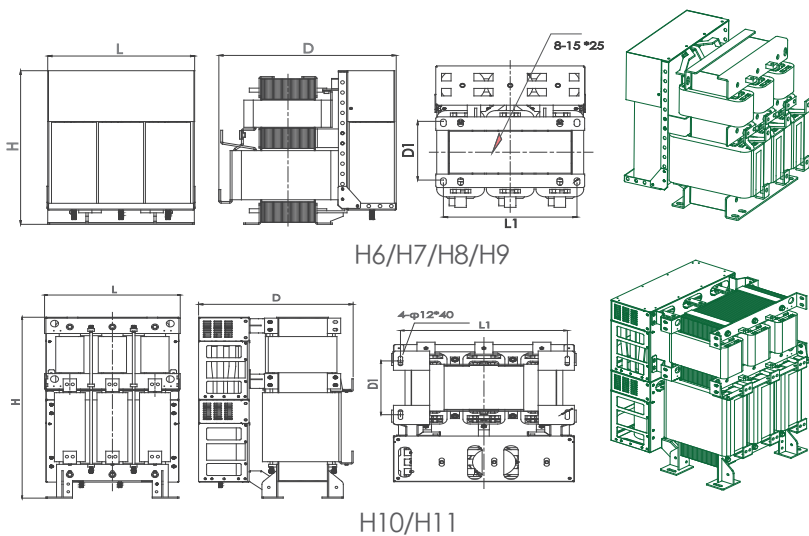

机型 model	尺寸Size (max)					
	L	D	H	L1	D1	A/B
H6	400	490	460	350/260	206	15*25
H7	430	570	735	380	202	12*40
H8	520	570	800	461	164	12*40
H9	520	575	840	461	184	12*40
H10	520	600	840	461	224	12*40
H11	520	615	840	461	224	12*40

谐波滤波器 B系列 380-415V-50Hz-5%-IP20 Harmonic filter Series B 380-415V-50Hz-5%-IP20

谐波滤波器型号 Harmonic filter type	额定负荷功率 [kW] Rated load power	电机驱动输入 电流 [Arms] Motor drive input current	额定滤波器输入 电流[Arms] Rated filter input current	净重 [kg] Net weight	毛重 [kg] Gross weight	典型损耗 [W] Typical loss	适配电缆 [m ²] Adapter cable	机型 model
HFR005X4SC001B06	0.4-1.5	1-3.7	0.5-2.2	10	17.5	29.5	06	H1
HFR005X4SC002B06	2.2	5	3.28	23	34.5	45	06	H1
HFR005X4SC005B06	3.7-5.5	10.5	8.2	30	37.5	75	06	H1
HFR005X4SC007B06	7.5	14.4	11.2	40	45	100	06	H1
HFR005X4SA011B10	11	22	16.5	50	60	125	10	H1
HFR005X4SA015B10	15	29	22.5	60	75	225	10	H2
HFR005X4SA022B16	18.5-22	40	32.5	60	90	300	16	H2
HFR005X4SA030B16	30	55	44.5	70	105	360	16	H2
HFR005X4SA037B35	37	66	54.8	80	120	420	35	H3
HFR005X4SA045B35	45	80	66.8	100	150	470	35	H3
HFR005X4SA055B50	55	96	81.8	110	165	560	50	H3
HFR005X4SA075B99	75	150	111	110	165	750	99	H4
HFR005X4SA090B99	90	180	134	120	180	850	99	H4
HFR005X4SA110B99	110	217	164	130	195	950	99	H4

谐波滤波器 B系列 380-415V-50Hz-5%-IP20 Harmonic filter Series B 380-415V-50Hz-5%-IP20

谐波滤波器型号 Harmonic filter type	额定负荷功率 [kW] Rated load power	电机驱动输入 电流 [Arms] Motor drive input current	额定滤波器输入 电流[Arms] Rated filter input current	净重 [kg] Net weight	毛重 [kg] Gross weight	典型损耗 [W] Typical loss	适配电缆 [m ²] Adapter cable	机型 model
HFR010X4SC001B06	0.4-1.5	1-3.7	0.5-2.2	10	17.5	29.5	06	H1
HFR010X4SC002B06	2.2	5	3.28	23	34.5	45	06	H1
HFR010X4SC005B06	3.7-5.5	10.5	8.2	30	37.5	75	06	H1
HFR010X4SC007B06	7.5	14.4	11.2	40	45	100	06	H1
HFR010X4SA011B10	11	22	16.5	50	60	125	10	H1
HFR010X4SA015B10	15	29	22.5	60	75	225	10	H2
HFR010X4SA022B16	18.5-22	40	32.5	60	90	300	16	H2
HFR010X4SA030B16	30	55	44.5	70	105	360	16	H2
HFR010X4SA037B35	37	66	54.8	80	120	420	35	H3
HFR010X4SA045B35	45	80	66.8	100	150	470	35	H3
HFR010X4SA055B50	55	96	81.8	110	165	560	50	H3
HFR010X4SA075B99	75	150	111	110	165	750	99	H4
HFR010X4SA090B99	90	180	134	120	180	850	99	H4
HFR010X4SA110B99	110	217	164	130	195	950	99	H4

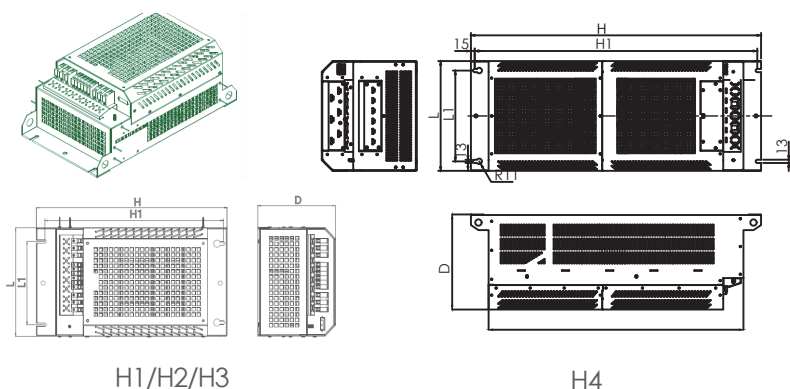

机型 model	尺寸Size (max)					
	L	D	H	L1	H1	A/B
H1	300	230	555	216	525	11*18
H2	410	275	650	350	640	11*15
H3	410	380	700	350	660	11*15
H4	450	390	1160	360	1120	11*15

谐波滤波器 N系列 380-415V-50Hz-5%-IP20 Harmonic filter Series N 380-415V-50Hz-5%-IP20

谐波滤波器型号 Harmonic filter type	额定负荷功率 [kW] Rated load power	电机驱动输入 电流 [Arms] Motor drive input current	额定滤波器输入 电流[Arms] Rated filter input current	净重 [kg] Net weight	毛重 [kg] Gross weight	典型损耗 [W] Typical loss	适配电缆 [m²] Adapter cable	机型 model
HFR005X4SC001N06	0.4-1.5	1-3.7	0.5-2.2	10	17.5	29.5	06	H1
HFR005X4SC002N06	2.2	5	3.28	23	34.5	45	06	H1
HFR005X4SC005N06	3.7-5.5	11	8.2	22	33	45	06	H1
HFR005X4SC007N06	7.5	15	11.2	28	42	75	06	H1
HFR005X4SC011N10	11	22	16.5	38	57	100	10	H2
HFR005X4SA015N10	15	30	22.5	48	72	125	10	H3
HFR005X4SA022N16	18.5-22	45	32.5	55	82.5	225	16	H4
HFR005X4SA030N16	30	60	44.5	66	99	300	16	H4
HFR005X4SA037N35	37	80	54.8	72	108	360	35	H4
HFR005X4SA045N35	45	90	66.8	93	139.5	420	35	H5
HFR005X4SA055N50	55	110	81.8	112	168	470	50	H6
HFR005X4SA075N99	75壁挂	150	111	125	187.5	560	99	H7
HFR005X4SA090N99	90壁挂	180	134	145	217.5	750	99	H8
HFR005X4SA110N99	110壁挂	217	164	165	247.5	850	99	H9
HFR005X4SA132N99	132壁挂	259	197	175	262.5	950	99	H10
HFR005X4SA160N99	160	290	240	385	577.5	1300	99	H11
HFR005X4SA200N99	200	370	296	430	645	1500	99	H11
HFR005X4SA250N99	220/250	520	356	485	727.5	1750	99	H11
HFR005X4SA315N99	315	580	444	520	780	2150	99	H11
HFR005X4SA355N99	355	650	500	570	855	2350	99	H11

谐波滤波器 N系列 380-415V-50Hz-5%-IP20 Harmonic filter Series N 380-415V-50Hz-5%-IP20

谐波滤波器型号 Harmonic filter type	额定负荷功率 [kW] Rated load power	电机驱动输入 电流 [Arms] Motor drive input current	额定滤波器输入 电流[Arms] Rated filter input current	净重 [kg] Net weight	毛重 [kg] Gross weight	典型损耗 [W] Typical loss	适配电缆 [m ²] Adapter cable	机型 model
HFR010X4SC001N06	0.4-1.5	1-3.7	0.5-2.2	10	17.5	29.5	06	H1
HFR010X4SC002N06	2.2	5	3.28	23	34.5	45	06	H1
HFR010X4SC005N06	3.7-5.5	11	8.2	22	33	45	06	H1
HFR010X4SC007N06	7.5	15	11.2	28	42	75	06	H1
HFR010X4SC011N10	11	22	16.5	38	57	100	10	H2
HFR010X4SA015N10	15	30	22.5	48	72	125	10	H3
HFR010X4SA022N16	18.5-22	45	32.5	55	82.5	225	16	H4
HFR010X4SA030N16	30	60	44.5	66	99	300	16	H4
HFR010X4SA037N35	37	80	54.8	72	108	360	35	H4
HFR010X4SA045N35	45	90	66.8	93	139.5	420	35	H5
HFR010X4SA055N50	55	110	81.8	112	168	470	50	H6
HFR010X4SA075N99	75壁挂	150	111	125	187.5	560	99	H7
HFR010X4SA090N99	90壁挂	180	134	145	217.5	750	99	H8
HFR010X4SA110N99	110壁挂	217	164	165	247.5	850	99	H9
HFR010X4SA132N99	132壁挂	259	197	175	262.5	950	99	H10
HFR010X4SA160N99	160	290	240	385	577.5	1300	99	H11
HFR010X4SA200N99	200	370	296	430	645	1500	99	H11
HFR010X4SA250N99	220/250	520	356	485	727.5	1750	99	H11
HFR010X4SA315N99	315	580	444	520	780	2150	99	H11
HFR010X4SA355N99	355	650	500	570	855	2350	99	H11

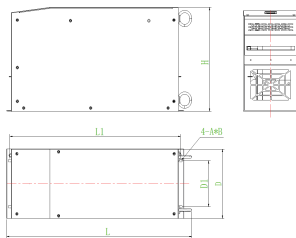

H1/H2/H3/H4/H5/H6

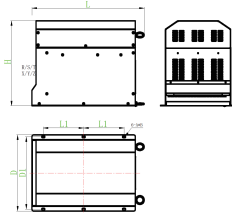

H7/H8/H9/H10

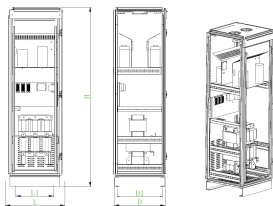

H11

机型 model	尺寸Size (max)					
	L	D	H	L1±2	D1±2	A/B
H1	415	235	215	355	165	φ16φ9
H2	460	265	270	390	200	φ16φ9
H3	585	340	355	490	270	φ16φ9
H4	715	245	350	650	150	φ16φ9
H5	750	330	370	675	150	φ16φ9
H6	750	330	370	675	150	6-10*20
H7	750	475	530	275*2	445	6-10*20
H8	750	475	580	275*2	445	6-10*20
H9	750	475	600	275*2	445	6-10*20
H10	750	475	600	275*2	445	4-φ13
H11	600	600	2200	535	525	4-φ13

注意! 选用时, 滤波器的功率与变频器的功率尽量匹配使用, 这时可以获得最佳的滤波效果, 不匹配时, 功率较大的滤波器可以用于功率较小的变频器, 但滤波效果会降低。

Attention! When selecting, try to match the power of the filter with the power of the frequency converter as much as possible, in order to achieve the best results Excellent filtering effect, when not matched, high-power filters can be used for low-power inverters, but The filtering effect will decrease.

接触器选型 Contactor selection

电流额定值 380-415V, 50HZ	HFR010 接触器	其他类型 AC3
A	类型	接触器额定值 ①kVAr
10	CI 9	1
14	CI 9	2
22	CI 9	4
29	CI 9	6
34	CI 16	7
40	CI 16	7
55	CI 61	9
66	CI 61	11
82	CI 61	15
96	CI 61	17
133	CI 61	22
171	CI 61	29
204	CI 61	36
251	CI 110	44
304	CI 110	51
325	CI 110	58
380	CI 110	66
480	CI 141	88

典型的功率电缆尺寸 Typical power cable size

额定负荷功率 @ 400 V/50 Hz[kW]	外形 尺寸	IEC		UC	
		铜电缆型号 mm ²	铝电缆型号 mm ²	铜电缆型号 AWG/kcmil	铝电缆型号 AWG/kcmil
0.4-1.5	H1	3*1.5	-	14	-
2.2	H1	3*1.5	-	14	-
3.7-5.5	H1	3*1.5	-	14	-
7.5	H1	3*2.5	-	14	-
11	H2	3*6	-	10	-
15	H3	3*10	-	10	-
18.5-22	H4	3*10	-	8	-
30	H4	3*16	-	8	-
37	H4	3*16	-	6	-
45	H5	3*25	3*35	6	-
55	H6	3*25	3*35	3	-
75壁挂	H7	3*35	3*50	3	-
90壁挂	H8	3*35	3*70	3	-
110壁挂	H9	3*50	3*70	3/0	-
132壁挂	H10	3*75	3*150	3/0	-
160	H11	3*120	3*150	3/0	-
200	H11	3*150	3*240	250MCM	-
220/250	H11	2*(3*95)	2*(3*120)	2*3/0	-
315	H11	2*(3*95)	2*(3*120)	2*3/0	-
355	H11	2*(3*150)	2*(3*240)	2*250MCM	-

附言:

Postscript:

谐波滤波器HFR005的功率因数负载的降低而降低。在无负载的情况下, 功率因数为0, 电容器可产生约为滤波器额定电流25%的超前无功电流!

The power factor of harmonic filter HFR005 decreases with the decrease of load. Under no load, with a power factor of 0, the capacitor can generate a leading reactive current of approximately 25% of the rated current of the filter!

当低于额定负载20%时, 需接触器断开调谐支路, 此项调节是满足功率因素的需求, 在20%额定负载时, 主路电感能够满足滤波需求, 若投切支路(调谐支路)使得设备功率因素降低, 无功电流变大, 很难满足整体需求。

When the load is below 20% of the rated load, the contactor needs to disconnect the tuning branch. This adjustment is to meet the power factor requirements. At 20% of the rated load, the main circuit inductance can meet the filtering requirements. If the switching of the tuning branch reduces the equipment power factor and increases the reactive current, it is difficult to meet the overall demand.

相反在负载高于20%时投切, 可以提高功率因素同时, 亦满足设备整体THDI指标需求。

On the contrary, switching when the load exceeds 20% can improve the power factor while also meeting the overall THDI index requirements of the equipment.

即: 当负载越接近满负荷时, HFR调谐支路的效果越亦明显, 整机的功率因素(PF)越高。

That is to say, as the load approaches full load, the effect of HFR tuning branch becomes more obvious, and the power factor (PF) of the whole machine is higher.

HFR滤波器的装置投切器, 可以在额定负载低于20% (设定值) 时, 自动设置投切调谐支路, 满足自动随动控制, 能够直观的显示谐波电流及总体THDI指标参数。

The device switching device of HFR filter can automatically set the switching tuning branch when the rated load is below 20% (set value), meeting the automatic follow-up control, and can intuitively display the harmonic current and overall THDI index parameters.